

# **GD5FXXQ4XBXIG**

## **DATASHEET**

## Contents

<b>1</b>	<b>FEATURE</b> .....	<b>4</b>
<b>2</b>	<b>GENERAL DESCRIPTION</b> .....	<b>5</b>
2.1	PRODUCT LIST .....	5
2.2	CONNECTION DIAGRAM .....	6
2.3	PIN DESCRIPTION .....	6
2.4	BLOCK DIAGRAM .....	7
<b>3</b>	<b>ARRAY ORGANIZATION</b> .....	<b>8</b>
3.1	MEMORY MAPPING .....	9
<b>4</b>	<b>DEVICE OPERATION</b> .....	<b>10</b>
4.1	SPI MODES .....	10
4.2	HOLD MODE .....	11
4.3	WRITE PROTECTION .....	11
<b>5</b>	<b>COMMANDS DESCRIPTION</b> .....	<b>12</b>
<b>6</b>	<b>WRITE OPERATIONS</b> .....	<b>13</b>
6.1	WRITE ENABLE (WREN) (06H) .....	13
6.2	WRITE DISABLE (WRDI) (04H) .....	13
<b>7</b>	<b>FEATURE OPERATIONS</b> .....	<b>14</b>
7.1	GET FEATURES (0FH) AND SET FEATURES (1FH) .....	14
<b>8</b>	<b>READ OPERATIONS</b> .....	<b>16</b>
8.1	PAGE READ.....	16
8.2	PAGE READ TO CACHE (13H).....	16
8.3	READ FROM CACHE (03H OR 0BH) .....	17
8.4	READ FROM CACHE X2 (3BH).....	17
8.5	READ FROM CACHE X4 (6BH).....	18
8.6	READ FROM CACHE DUAL IO (BBH) .....	19
8.7	READ FROM CACHE QUAD IO (EBH).....	20
<b>9</b>	<b>READ ID (9FH)</b> .....	<b>21</b>
<b>10</b>	<b>PROGRAM OPERATIONS</b> .....	<b>22</b>
10.1	PAGE PROGRAM .....	22
10.2	PROGRAM LOAD (PL) (02H) .....	22
10.3	PROGRAM LOAD X4 (PL x4) (32H).....	23
10.4	PROGRAM EXECUTE (PE) (10H).....	24
10.5	INTERNAL DATA MOVE .....	25
10.6	PROGRAM LOAD RANDOM DATA (84H) .....	25
10.7	PROGRAM LOAD RANDOM DATA X4 (C4H/34H).....	26



---

10.8	PROGRAM LOAD RANDOM DATA QUAD IO (72H).....	27
<b>11</b>	<b>ERASE OPERATIONS .....</b>	<b>28</b>
11.1	BLOCK ERASE (D8H) .....	28
<b>12</b>	<b>RESET OPERATIONS.....</b>	<b>29</b>
12.1	RESET (FFH).....	29
<b>13</b>	<b>ADVANCED FEATURES .....</b>	<b>30</b>
13.1	OTP REGION .....	30
13.2	BLOCK PROTECTION .....	31
13.3	STATUS REGISTER AND DRIVER REGISTER.....	32
13.4	ASSISTANT BAD BLOCK MANAGEMENT .....	33
13.5	INTERNAL ECC .....	34
<b>14</b>	<b>POWER ON TIMING .....</b>	<b>35</b>
<b>15</b>	<b>ABSOLUTE MAXIMUM RATINGS .....</b>	<b>36</b>
<b>16</b>	<b>CAPACITANCE MEASUREMENT CONDITIONS.....</b>	<b>37</b>
<b>17</b>	<b>DC CHARACTERISTIC .....</b>	<b>38</b>
<b>18</b>	<b>AC CHARACTERISTICS.....</b>	<b>39</b>
<b>19</b>	<b>PERFORMANCE TIMING .....</b>	<b>40</b>
<b>20</b>	<b>ORDERING INFORMATION .....</b>	<b>42</b>
<b>21</b>	<b>PACKAGE INFORMATION .....</b>	<b>43</b>
<b>22</b>	<b>REVISION HISTORY.....</b>	<b>46</b>

## 1 FEATURE

- ◆ Page Size
  - 2048 bytes page for read and program, spare 128bytes
- ◆ Standard, Dual, Quad SPI
  - Standard SPI: SCLK, CS#, SI, SO, WP#, HOLD#
  - Dual SPI: SCLK, CS#, SIO0, SIO1, WP#, HOLD#
  - Quad SPI: SCLK, CS#, SIO0, SIO1, SIO2, SIO3
- ◆ High Speed Clock Frequency
  - 120MHz for fast read with 30PF load
  - Quad I/O Data transfer up to 480Mbits/s
- ◆ Software/Hardware Write Protection
  - Write protect all/portion of memory via software
  - Enable/Disable protection with WP# Pin
  - Top or Bottom, Block selection combination
- ◆ Advanced security Features
  - 8K-Byte OTP Region
- ◆ Single Power Supply Voltage
  - Full voltage range for 1.8V: 1.7V ~ 2.0V
  - Full voltage range for 3.3V: 2.7V ~ 3.6V
- ◆ Program/Erase/Read Speed
  - Page Program time: 400us typical
  - Block Erase time: 3ms typical
  - Page read time: 80us maximum(w/I ECC)
- ◆ Low Power Consumption
  - 40mA maximum active current
  - 70uA maximum standby current
- ◆ Enhanced access performance
  - 2kbyte cache for fast random read
  - Cache read and cache program
- ◆ Advanced Feature for NAND
  - Internal ECC option, per 528bytes
  - Internal data move by page with ECC

## 2 GENERAL DESCRIPTION

SPI (Serial Peripheral Interface) NAND Flash provides an ultra cost-effective while high density non-volatile memory storage solution for embedded systems, based on an industry-standard NAND Flash memory core. It is an attractive alternative to SPI-NOR and standard parallel NAND Flash, with advanced features:

- Total pin count is 8, including VCC and GND
- Density range from 1G bit to 2G bit
- Superior write performance and cost per bit over SPI-NOR
- Significant low cost than parallel NAND

This low-pin-count NAND Flash memory follows the industry-standard serial peripheral interface, and always remains the same pinout from one density to another. The command sets resemble common SPI-NOR command sets, modified to handle NAND specific functions and added new features. GigaDevice SPI NAND is an easy-to-integrate NAND Flash memory, with specified designed features to ease host management:

- **User-selectable internal ECC.** ECC code is generated internally during a page program operation. When a page is read to the cache register, the ECC code is detect and correct the errors when necessary. The 64-bytes spare area is available even when internal ECC enabled. The device outputs corrected data and returns an ECC error status.
- **Internal data move or copy back with internal ECC.** The device can be easily refreshed and manage garbage collection task, without need of shift in and out of data.
- **Power on Read with internal ECC.** The device will automatically read first page of fist block to cache after power on, then host can directly read data from cache for easy boot. Also the data is promised correctly by internal ECC.

It is programmed and read in page-based operations, and erased in block-based operations. Data is transferred to or from the NAND Flash memory array, page by page, to a data register and a cache register. The cache register is closest to I/O control circuits and acts as a data buffer for the I/O data; the data register is closest to the memory array and acts as a data buffer for the NAND Flash memory array operation. The cache register functions as the buffer memory to enable page and random data READ/WRITE and copy back operations. These devices also use a SPI status register that reports the status of device operation.

### 2.1 Product List

Vcc Range	Part No.	Page Size
1.7V ~ 2.0V	GD5F1GQ4RBYIG	2Kbytes + 128bytes
	GD5F2GQ4RBYIG	
	GD5F2GQ4RBZIG	
	GD5F1GQ4RBZIG	
2.7V ~ 3.6V	GD5F1GQ4UBYIG	
	GD5F2GQ4UBYIG	
	GD5F1GQ4UBZIG	
	GD5F2GQ4UBZIG	

## 2.2 Connection Diagram

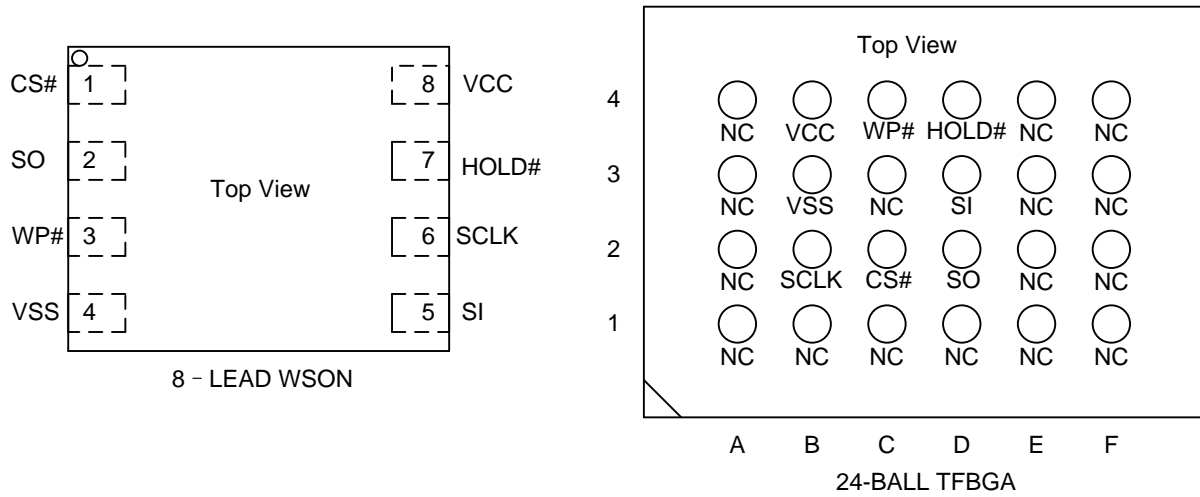

## 2.3 Pin Description

Pin Name	I/O	Description
CS#	I	Chip Select input, active low
SO/SIO1	I/O	Serial Data Output / Serial Data Input Output 1
WP#/SIO2	I/O	Write Protect, active low / Serial Data Input Output 2
VSS	Ground	Ground
SI/SIO0	I/O	Serial Data Input / Serial Data Input Output 0
SCLK	I	Serial Clock input
HOLD#/SIO3	I/O	Hold input, active low / Serial Data Input Output3
VCC	Supply	Power Supply

2.4 Block Diagram

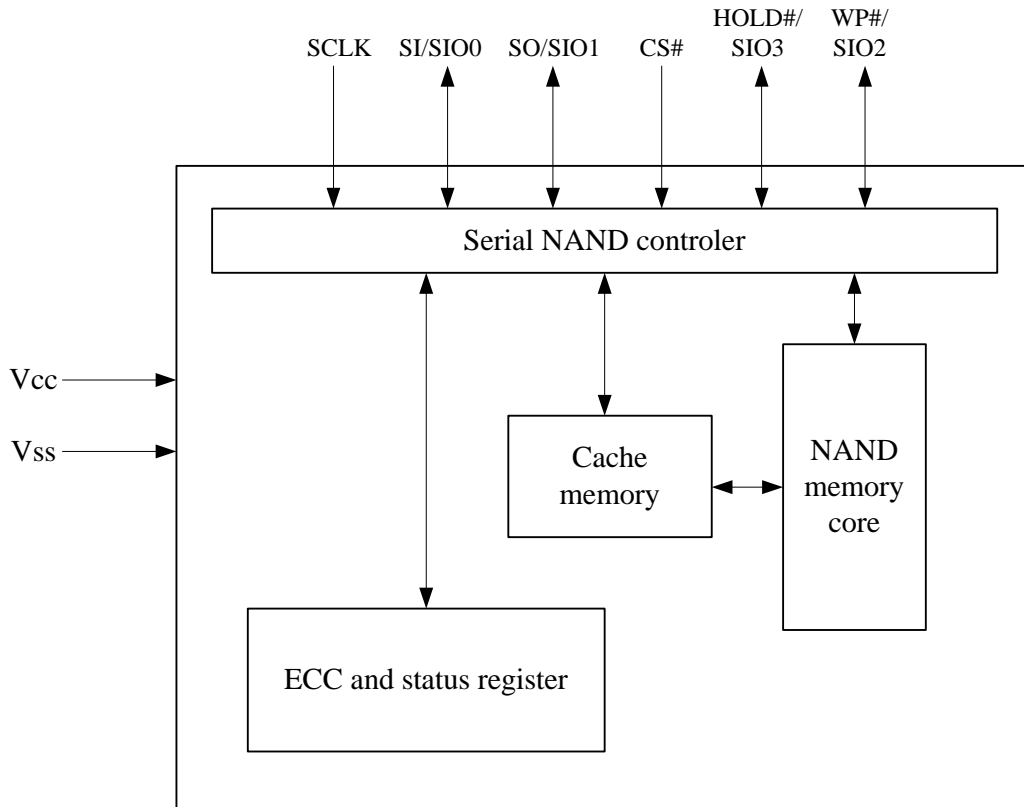

### 3 ARRAY ORGANIZATION

Each block has	Each page has	
128K+8K	2K+128	bytes
64	-	pages
-	-	blocks

Figure1. Array Organization

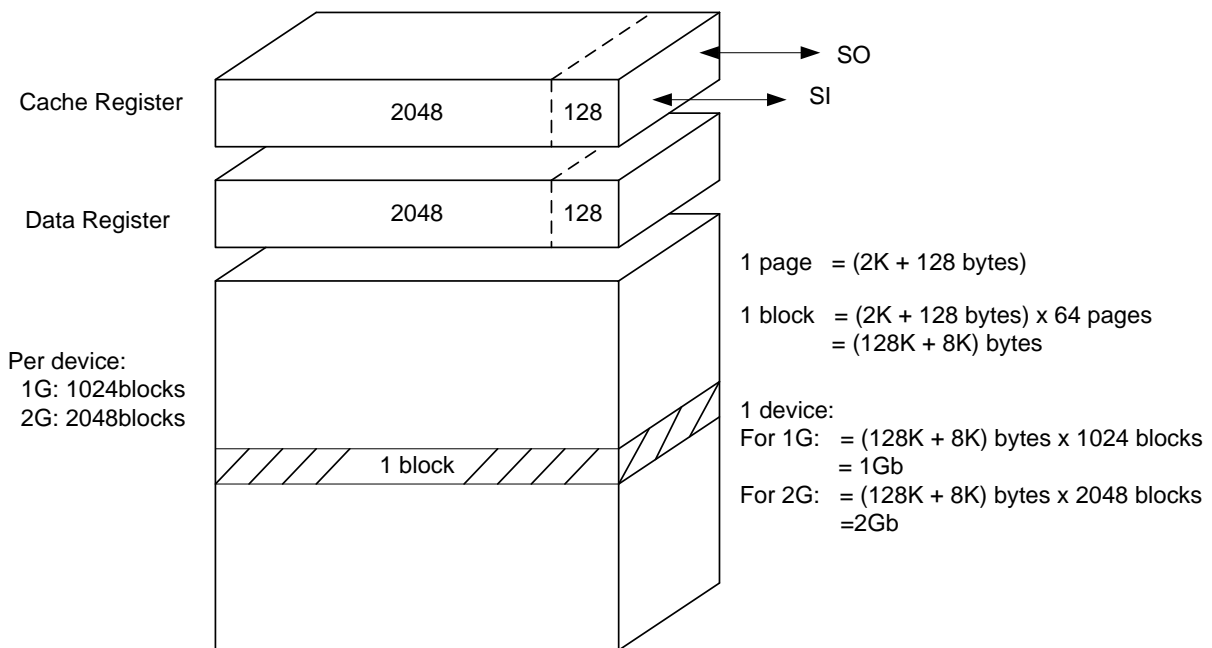



### 3.1 Memory Mapping

FOR 1G:

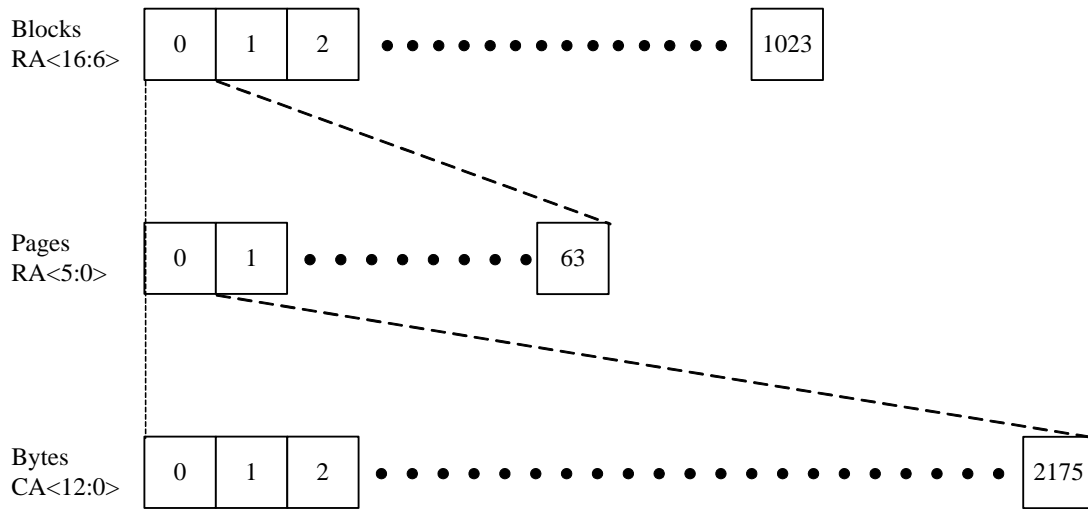

Note:

1. CA: Column Address. The 12-bit address is capable of addressing from 0 to 4095 bytes; however, only bytes 0 through 2175 are valid. Bytes 2176 through 4095 of each page are “out of bounds,” do not exist in the device, and cannot be addressed.
2. RA: Row Address. RA<5:0> selects a page inside a block, and RA<15:6> selects a block.

For 2G:

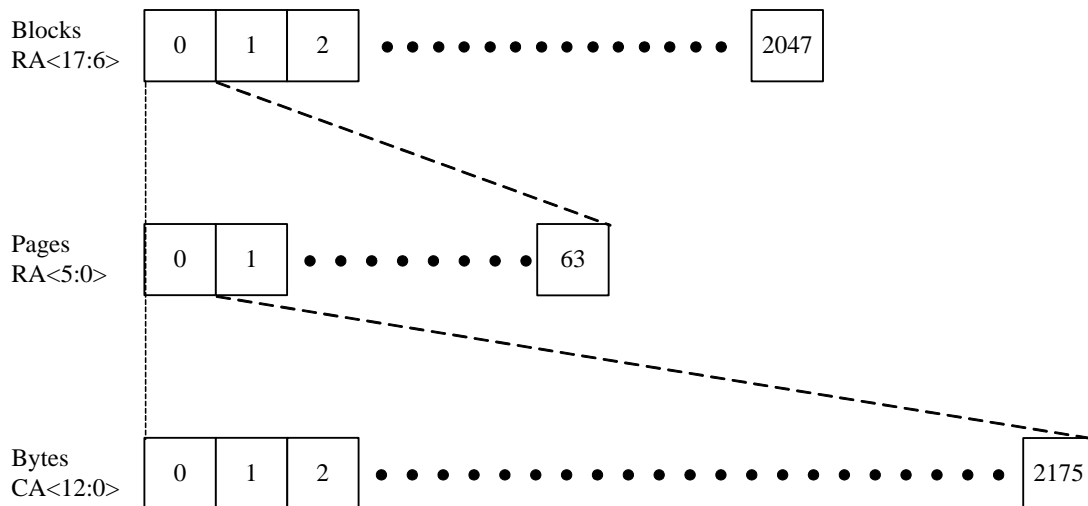

Note:

1. CA: Column Address. The 12-bit address is capable of addressing from 0 to 4095 bytes; however, only bytes 0 through 2175 are valid. Bytes 2176 through 4095 of each page are “out of bounds,” do not exist in the device, and cannot be addressed.
2. RA: Row Address. RA<5:0> selects a page inside a block, and RA<16:6> selects a block.

## 4 DEVICE OPERATION

### 4.1 SPI Modes

SPI NAND supports two SPI modes:

- CPOL = 0, CPHA = 0 (Mode 0)
- CPOL = 1, CPHA = 1 (Mode 3)

Input data is latched on the rising edge of SCLK and data shifts out on the falling edge of SCLK for both modes. All timing diagrams shown in this data sheet are mode 0. See figure2 for more details.

**Figure2. SPI Modes Sequence Diagram**

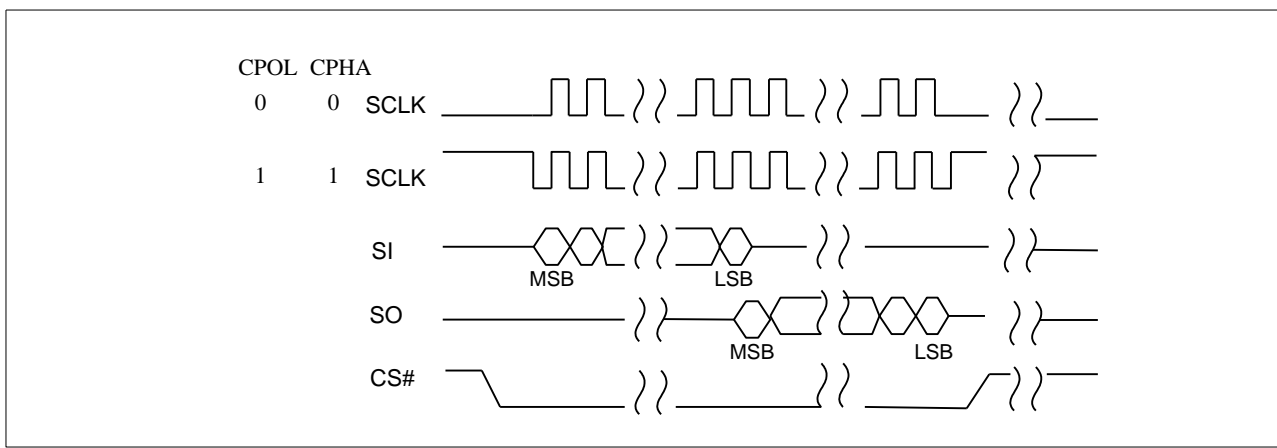

Note: While CS# is HIGH, keep SCLK at VCC or GND (determined by mode 0 or mode 3).

#### Standard SPI

SPI NAND Flash features a standard serial peripheral interface on 4 signals bus: Serial Clock (SCLK), Chip Select (CS#), Serial Data Input (SI) and Serial Data Output (SO).

#### Dual SPI

SPI NAND Flash supports Dual SPI operation when using the x2 and dual IO commands. These commands allow data to be transferred to or from the device at two times the rate of the standard SPI. When using the Dual SPI command the SI and SO pins become bidirectional I/O pins: SIO0 and SIO1.

#### Quad SPI

SPI NAND Flash supports Quad SPI operation when using the x4 and Quad IO commands. These commands allow data to be transferred to or from the device at four times the rate of the standard SPI. When using the Quad SPI command the SI and SO pins become bidirectional I/O pins: SIO0 and SIO1, and WP# and HOLD# pins become SIO2 and SIO3.

### 4.2 HOLD Mode

The HOLD# signal goes low to stop any serial communications with the device, but doesn't stop the operation of write status register, programming, or erasing in progress.

The operation of HOLD, need CS# keep low, and starts on falling edge of the HOLD# signal, with SCLK signal being low (if SCLK is not being low, HOLD operation will not start until SCLK being low). The HOLD condition ends on rising edge of HOLD# signal with SCLK being low (If SCLK is not being low, HOLD operation will not end until SCLK being low).

The SO is high impedance, both SI and SCLK don't care during the HOLD operation, if CS# drives high during HOLD operation, it will reset the internal logic of the device. To re-start communication with chip, the HOLD# must be at high and then CS# must be at low.

Figure3. Hold Condition

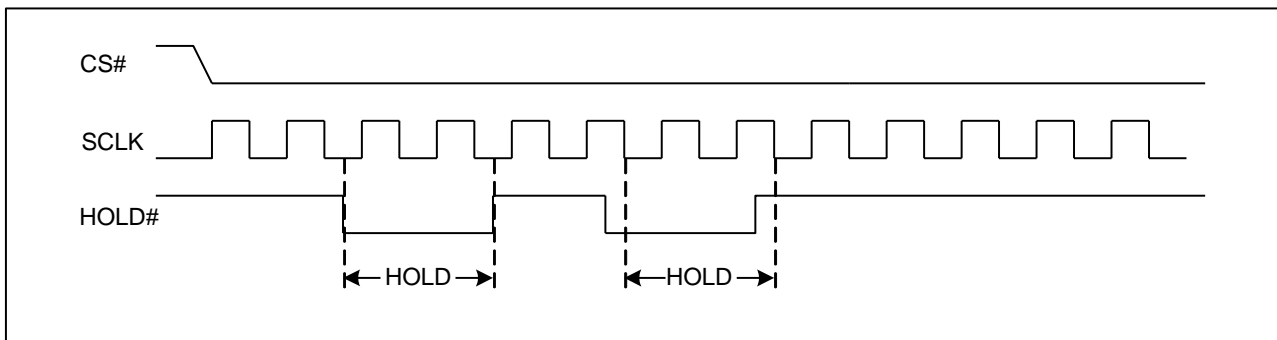

### 4.3 Write Protection

SPI NAND provides Hardware Protection Mode besides the Software Mode. Write Protect (WP#) prevents the block lock bits (BP0, BP1, BP2 and INV, CMP) from being overwritten. If the BRWD bit is set to 1 and WP# is LOW, the block protect bits cannot be altered.

## 5 COMMANDS DESCRIPTION

Table1. Commands Set

Command Name	Byte 1	Byte 2	Byte 3	Byte 4	Byte 5	Byte N
Write Enable	06H					
Write Disable	04H					
Get Features	0FH	A7-A0	(D7-D0)			Wrap
Set Feature	1FH	A7-A0	(D7-D0)	dummy <sup>(1)</sup>		
Page Read (to cache)	13H	A23-A16	A15-A8	A7-A0		
Read From Cache	03H/0BH	A15-A8 <sup>(4)</sup>	A7-A0	dummy <sup>(2)</sup>	(D7-D0)	
Read From Cache x 2	3BH	A15-A8 <sup>(4)</sup>	A7-A0	dummy <sup>(2)</sup>	(D7-D0)x2	
Read From Cache x 4	6BH	A15-A8 <sup>(4)</sup>	A7-A0	dummy <sup>(2)</sup>	(D7-D0)x4	
Read From Cache Dual IO	BBH	A15-A0 <sup>(4)</sup>	dummy <sup>(3)</sup>	(D7-D0)x2		
Read From Cache Quad IO	EBH	A15-A0 <sup>(5)</sup>	(D7-D0)x4			
Read ID <sup>(8)</sup>	9FH	A7-A0	MID	DID		Wrap
Program Load	02H	A15-A8 <sup>(6)</sup>	A7-A0	(D7-D0)	Next byte	Byte N
Program Load x4	32H	A15-A8 <sup>(6)</sup>	A7-A0	(D7-D0)x4	Next byte	Byte N
Program Execute	10H	A23-A16	A15-A8	A7-A0		
Program Load Random Data	84H <sup>(10)</sup>	A15-A8 <sup>(6)</sup>	A7-A0	(D7-D0)	Next byte	Byte N
Program Load Random Data x4	C4H/34H <sup>(10)</sup>	A15-A8 <sup>(6)</sup>	A7-A0	(D7-D0)x4	Next byte	Byte N
Program Load Random Data Quad IO	72H	A15-A0 <sup>(7)</sup>	(D7-D0)x4	Next byte		Byte N
Block Erase(128K)	D8H	A23-A16	A15-A8	A7-A0		
Reset <sup>(9)</sup>	FFH					

Notes:

- The dummy byte can be inputted or not.
- The x8 clock = dummy<7:0>.
- The x8 clock = dummy<7:0>, D7-D0.
- The x8 clock = dummy<3:0>, A11-A8 or dummy<3:0>, A11-A0.
- The x8 clock = dummy<3:0>, A11-A0, dummy<7:0>, D7-D0.
- The x8 clock = dummy<3:0>, A<11:8>.
- The x8 clock = dummy<3:0>, A<11:0>, D7-D0, D7-D0.
- MID is Manufacture ID (C8h for GigaDevice), DID is Device ID  
When A7-A0 is 00h, read MID and DID.
- Reset command:
  - During busy, Reset will reset PAGE READ/PROGRAM/ERASE operation.
  - During idle, Reset will reset status register bits P\_FAIL/E\_FAIL/ECCS bits.
- Those commands are only available in Internal Data Move operation.

## 6 WRITE OPERATIONS

### 6.1 Write Enable (WREN) (06H)

The Write Enable (WREN) command is for setting the Write Enable Latch (WEL) bit. The Write Enable Latch (WEL) bit must be set prior to following operations that change the contents of the memory array:

- Page program
- OTP program/OTP protection
- Block erase

The WEL bit can be cleared after a reset command.

Figure4. Write Enable Sequence Diagram

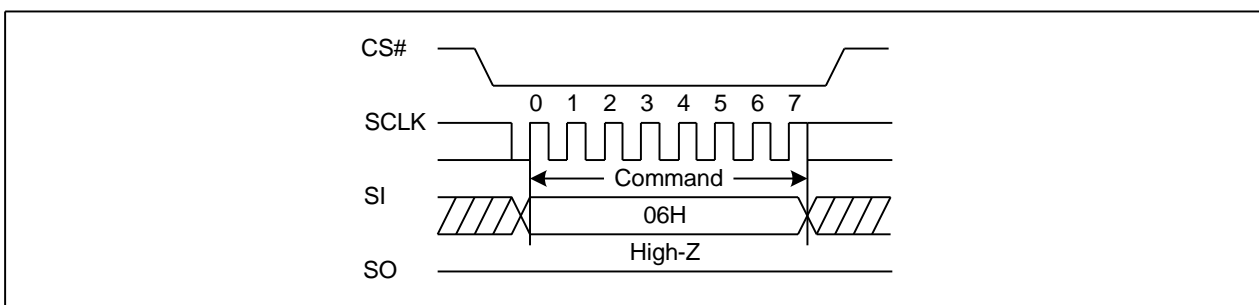

### 6.2 Write Disable (WRDI) (04H)

The Write Disable command is for resetting the Write Enable Latch (WEL) bit. The WEL bit is reset by following condition:

- Page program
- OTP program/OTP protection
- Block erase

Figure5. Write Disable Sequence Diagram

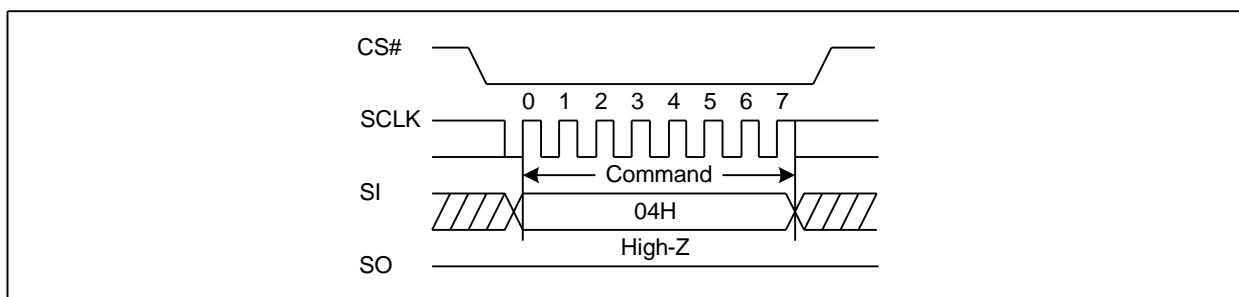

## 7 FEATURE OPERATIONS

### 7.1 Get Features (0FH) and Set Features (1FH)

The GET FEATURES (0FH) and SET FEATURES (1FH) commands are used to monitor the device status and alter the device behavior. These commands use a 1-byte feature address to determine which feature is to be read or modified. Features such as OTP and block locking can be enabled or disabled by setting specific feature bits (shown in the following table). The status register is mostly read, except WEL, which is a writable bit with the WRITE ENABLE (06H) command. When a feature is set, it remains active until the device is power cycled or the feature is written to. Unless otherwise specified in the following table, once the device is set, it remains set, even if a RESET (FFH) command is issued.

**Table2. Features Settings**

Register	Addr.	7	6	5	4	3	2	1	0
Protection	A0H	BRWD	Reserved	BP2	BP1	BP0	INV	CMP	Reserved
Feature	B0H	OTP_PRT	OTP_EN	Reserved	ECC_EN	Reserved	Reserved	Reserved	QE
Status	C0H	Reserved	Reserved	ECCS1	ECCS0	P_FAIL	E_FAIL	WEL	OIP
Feature	D0H	Reserved	DS_S1	DS_S0	Reserved	Reserved	Reserved	Reserved	Reserved
Status	F0H	Reserved	Reserved	ECCSE1	ECCSE0	Reserved	Reserved	Reserved	Reserved

Note: If BRWD is enabled and WP# is LOW, then the block lock register cannot be changed.

If QE is enabled, the quad IO operations can be executed.

All the reserved bits must be held low when the feature is set.

00h is the default data byte value for Output Driver Register after power-up.

**Figure6. Get Features Sequence Diagram**

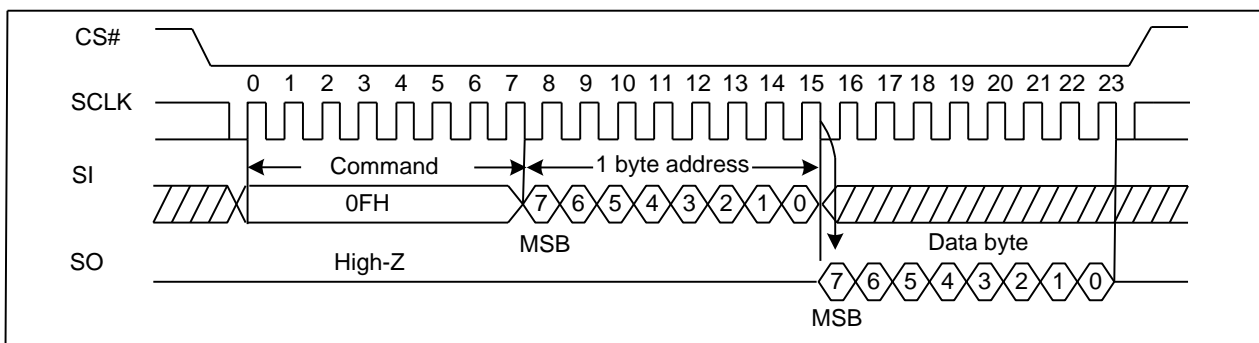

The set features command supports a dummy byte mode after the data byte as well. The features in the feature byte B0H are all volatile except OTP\_PRT bit.

Figure7. Set Features Sequence Diagram

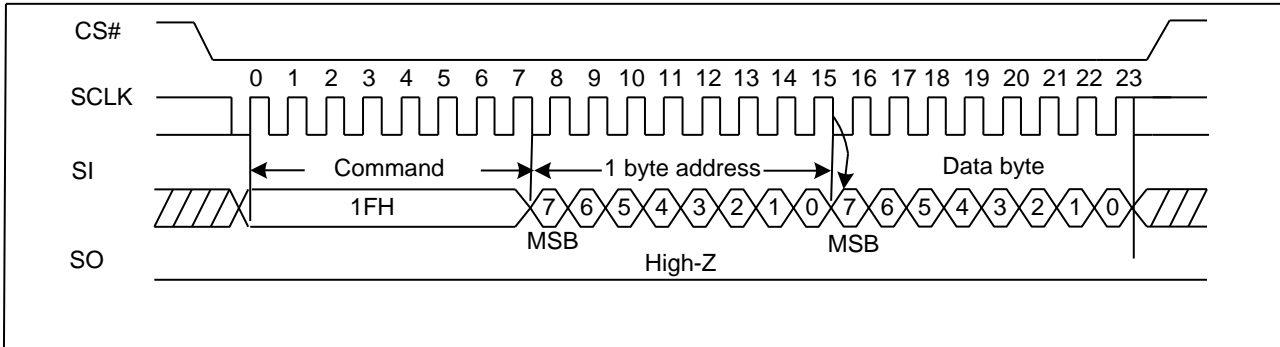

## 8 READ OPERATIONS

### 8.1 Page Read

The PAGE READ (13H) command transfers the data from the NAND Flash array to the cache register. The command sequence is as follows:

- 13H (PAGE READ to cache)
- 0FH (GET FEATURES command to read the status)
- 03H or 0BH (Read from cache)/3BH (Read from cache x2)/6BH (Read from cache x4)/BBH (Read from cache dual IO)/EBH (Read from cache quad IO)

The PAGE READ command requires a 24-bit address. After the block/page addresses are registered, the device starts the transfer from the main array to the cache register, and is busy for  $t_{RD}$  time. During this time, the GET FEATURE (0FH) command can be issued to monitor the status. Followed the page read operation, the RANDOM DATA READ (03H/0BH/3BH/6BH/BBH/EBH) command must be issued in order to read out the data from cache. The output data starts at the initial address specified in the command, once it reaches the ending boundary of the 2176-byte section, the output will wrap around the beginning boundary automatically until CS# is pulled high to terminate this operation. Refer waveforms to view the entire READ operation.

### 8.2 Page Read to Cache (13H)

Figure8. Page Read to cache Sequence Diagram

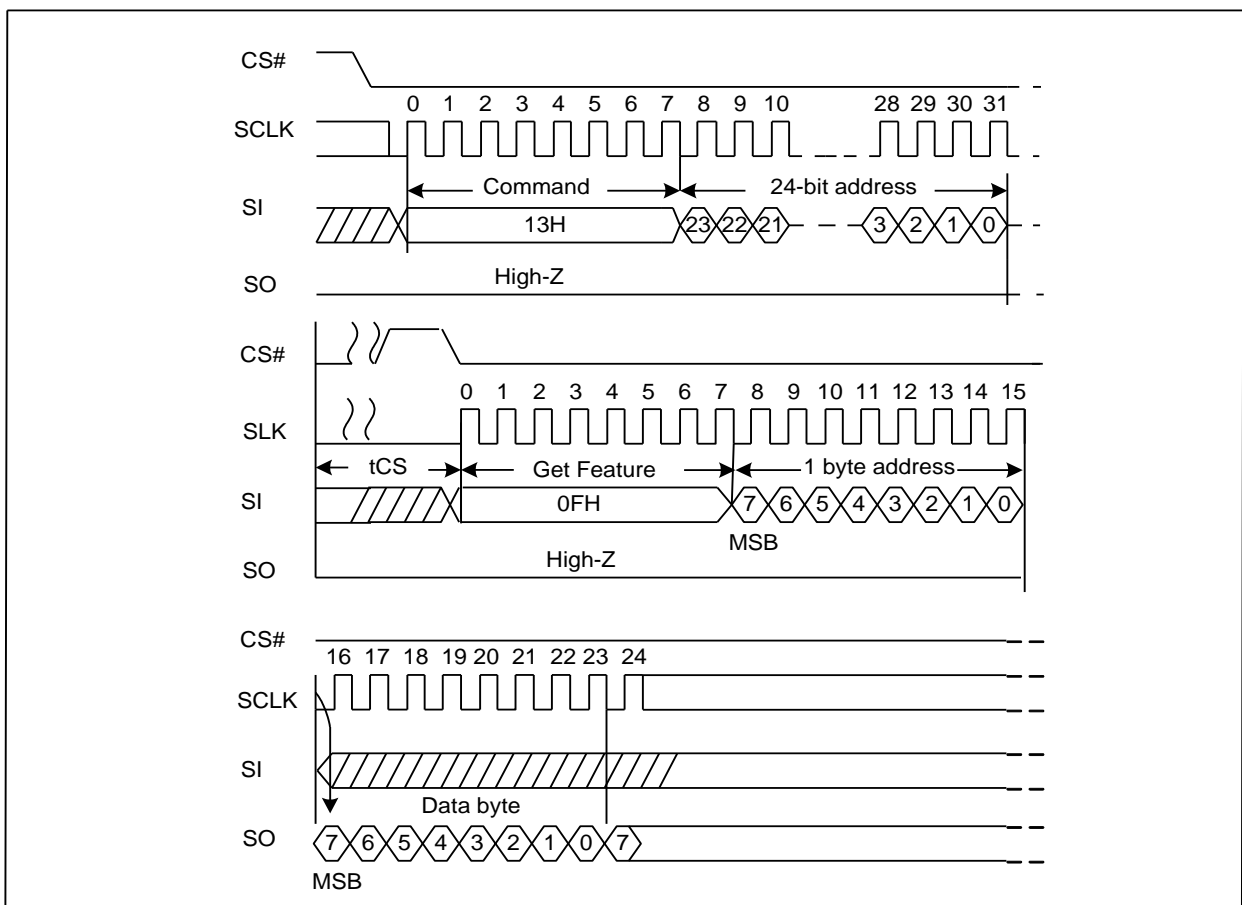



### 8.3 Read From Cache (03H or 0BH)

Figure9. Read From Cache Sequence Diagram

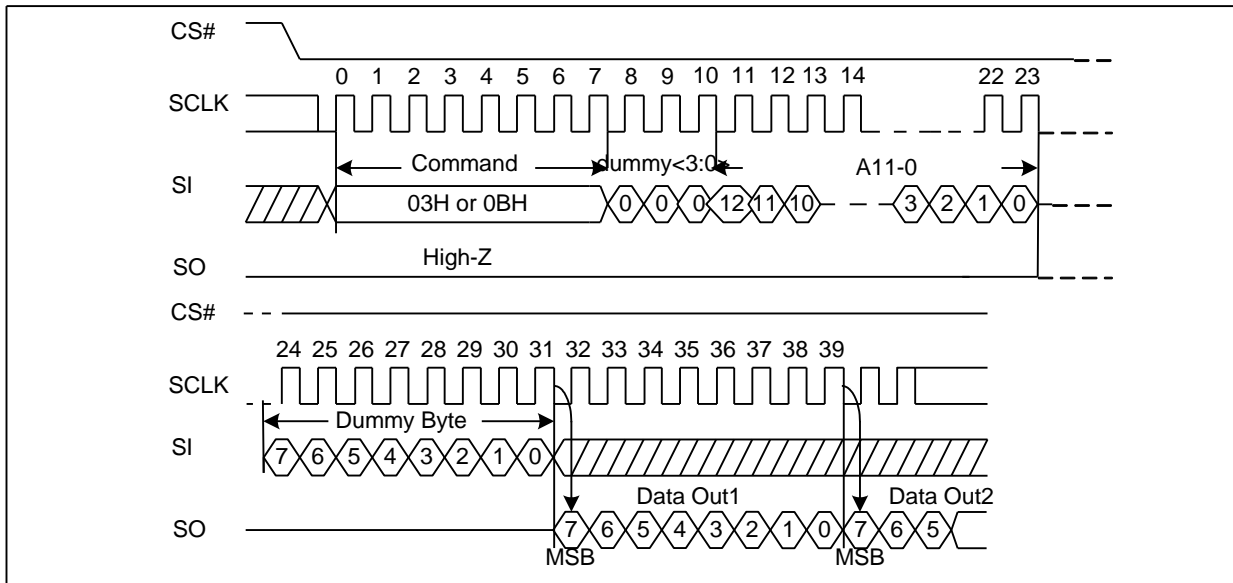

### 8.4 Read From Cache x2 (3BH)

Figure10. Read From Cache x2 Sequence Diagram

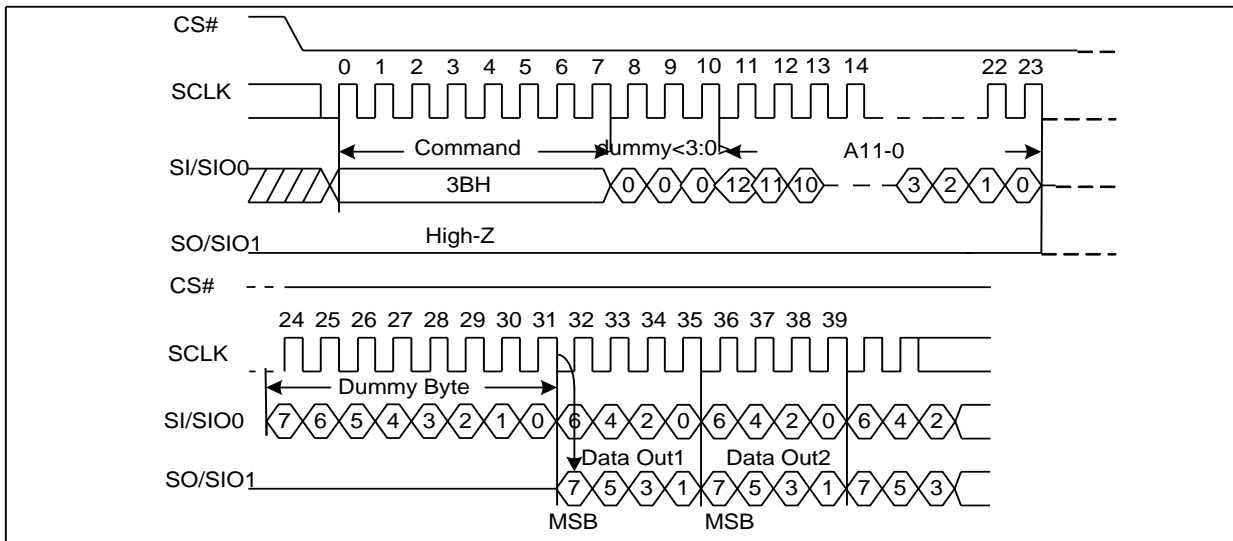

### 8.5 Read From Cache x4 (6BH)

The Quad Enable bit (QE) of feature (B0[0]) must be set to enable the read from cache x4 command.

Figure11. Read From Cache x4 Sequence Diagram

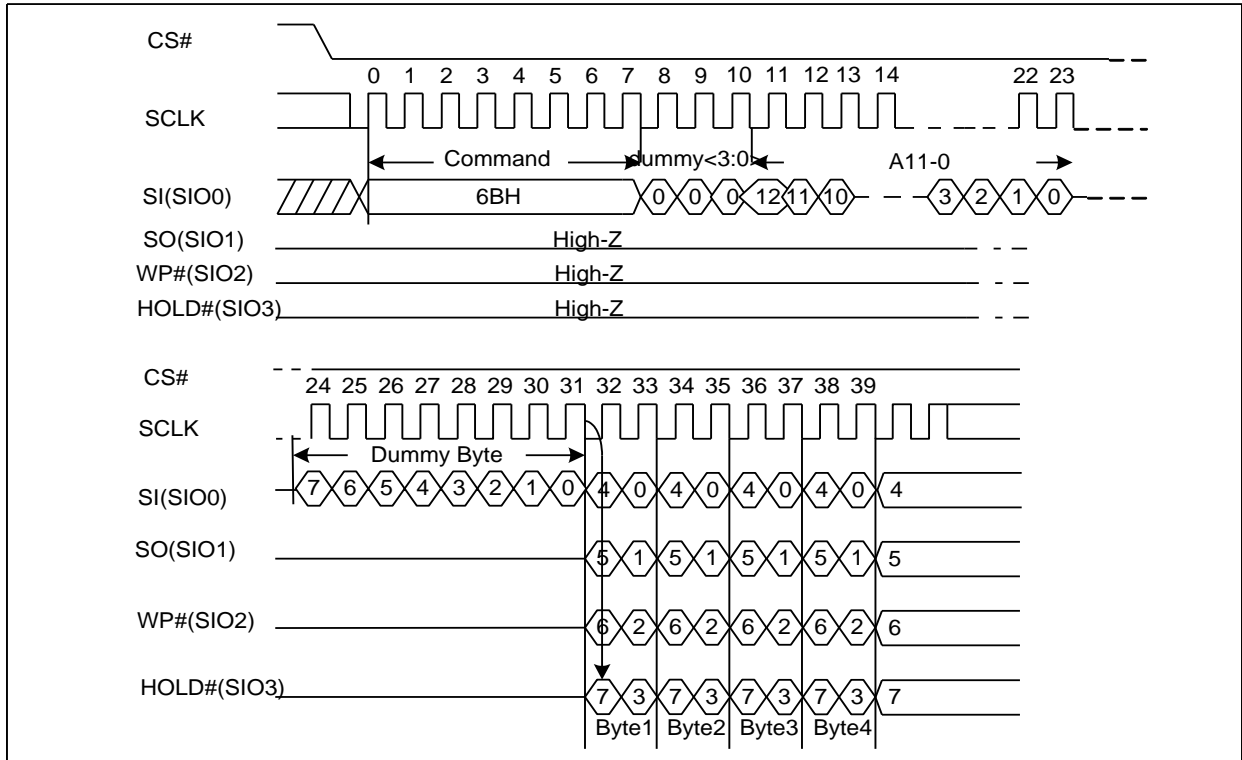

### 8.6 Read From Cache Dual IO (BBH)

The Read from Cache Dual I/O command (BBH) is similar to the Read from Cache x2 command (3BH) but with the capability to input the 4 Dummy bits, followed by a 12-bit column address for the starting byte address and a dummy byte by SIO0 and SIO1, each bit being latched in during the rising edge of SCLK, then the cache contents are shifted out 2-bit per clock cycle from SIO0 and SIO1. The first address byte can be at any location. The address increments automatically to the next higher address after each byte of data shifted out until the boundary wrap bit.

Figure12. Read From Cache Dual IO Sequence Diagram

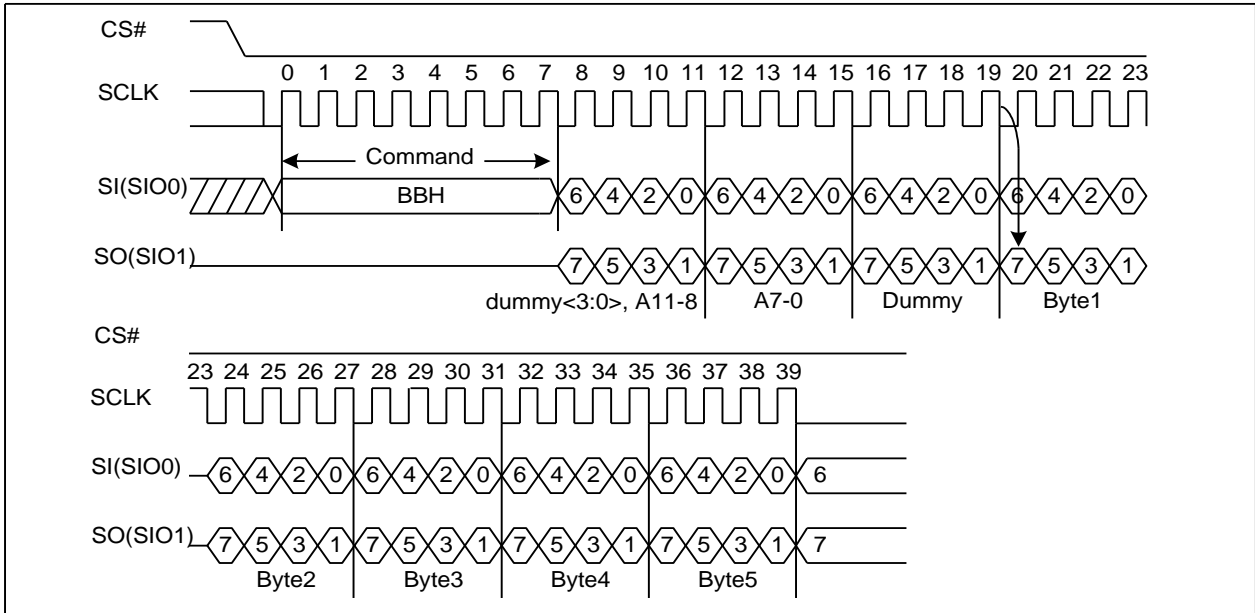

### 8.7 Read From Cache Quad IO (EBH)

The Read from Cache Quad IO command is similar to the Read from Cache x4 command but with the capability to input the 4 dummy bits, followed a 12-bit column address for the starting byte address and a dummy byte by SIO0, SIO1, SIO3, SIO4, each bit being latched in during the rising edge of SCLK, then the cache contents are shifted out 4-bit per clock cycle from SIO0, SIO1, SIO2, SIO3. The first byte addressed can be at any location. The address is automatically incremented to the next higher address after each byte of data is shifted out until the boundary wrap bit. The Quad Enable bit (QE) of feature (B0[0]) must be set to enable the read from cache quad IO command.

Figure13. Read From Cache Quad IO Sequence Diagram

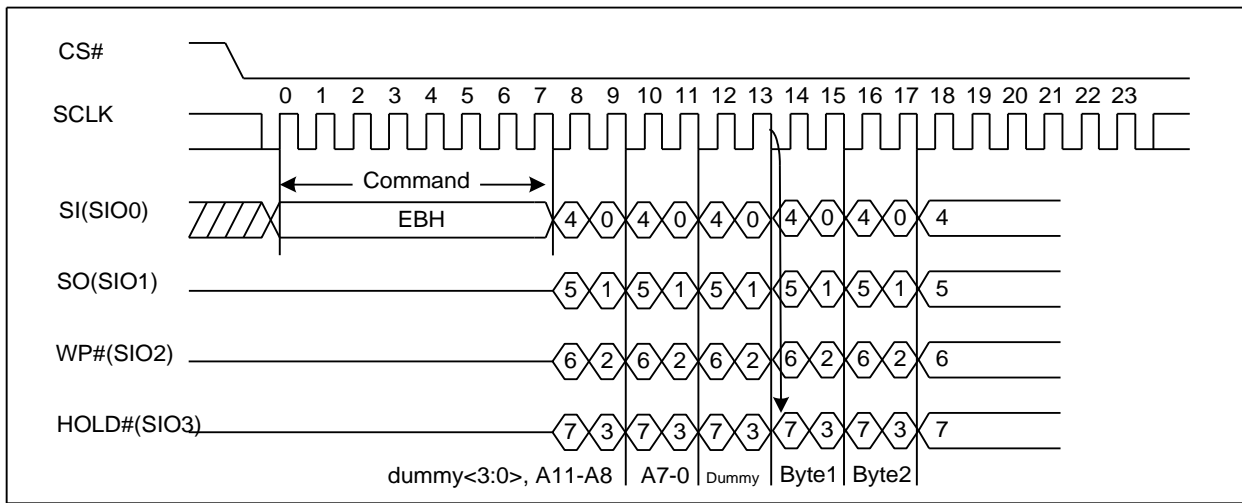

## 9 Read ID (9FH)

The READ ID command is used to identify the NAND Flash device.

- With address 00H-01H, the READ ID command outputs the Manufacturer ID and the device ID. See Table 4 for details.

Figure14. Read ID Sequence Diagram

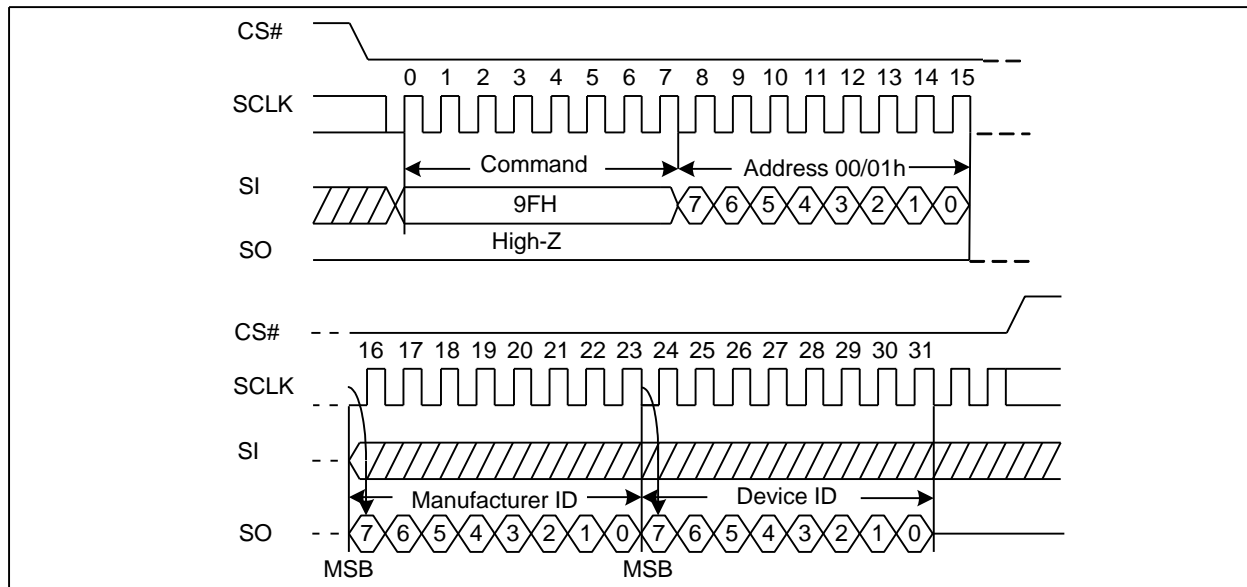

Table4. READ ID Table

Address	Part No	Value	Page Size	Description
00H	GD5FXXQ4U	C8h	2KByte + 128Byte	Manufacture ID (GigaDevice)
	GD5FXXQ4R			
01H	GD5F1GQ4U	D1h		Device ID (SPI NAND 1Gbit 3.3V)
	GD5F2GQ4U	D2h		Device ID (SPI NAND 2Gbit 3.3V)
	GD5F1GQ4R	C1h		Device ID (SPI NAND 1Gbit 1.8V)
	GD5F2GQ4R	C2h		Device ID (SPI NAND 2Gbit 1.8V)

## 10 PROGRAM OPERATIONS

### 10.1 Page Program

The PAGE PROGRAM operation sequence programs 1 byte to 2176 bytes of data within a page. The page program sequence is as follows:

- 02H (PROGRAM LOAD)/32H (PROGRAM LOAD x4)
- 06H (WRITE ENABLE)
- 10H (PROGRAM EXECUTE)
- 0FH (GET FEATURE command to read the status)

Firstly, a PROGRAM LOAD (02H/32H) command is issued. PROGRAM LOAD consists of an 8-bit Op code, followed by 4 dummy bits and a 12-bit column address, then the data bytes to be programmed. The data bytes are loaded into a cache register that is 2176 bytes long. If more than 2176 bytes are loaded, then those additional bytes are ignored by the cache register. The command sequence ends when CS# goes from LOW to HIGH. Figure16 shows the PROGRAM LOAD operation. Secondly, prior to performing the PROGRAM EXECUTE operation, a WRITE ENABLE (06H) command must be issued. As with any command that changes the memory contents, the WRITE ENABLE must be executed in order to set the WEL bit. If this command is not issued, then the rest of the program sequence is ignored.

### 10.2 Program Load (PL) (02H)

Figure15. Program Load Sequence Diagram

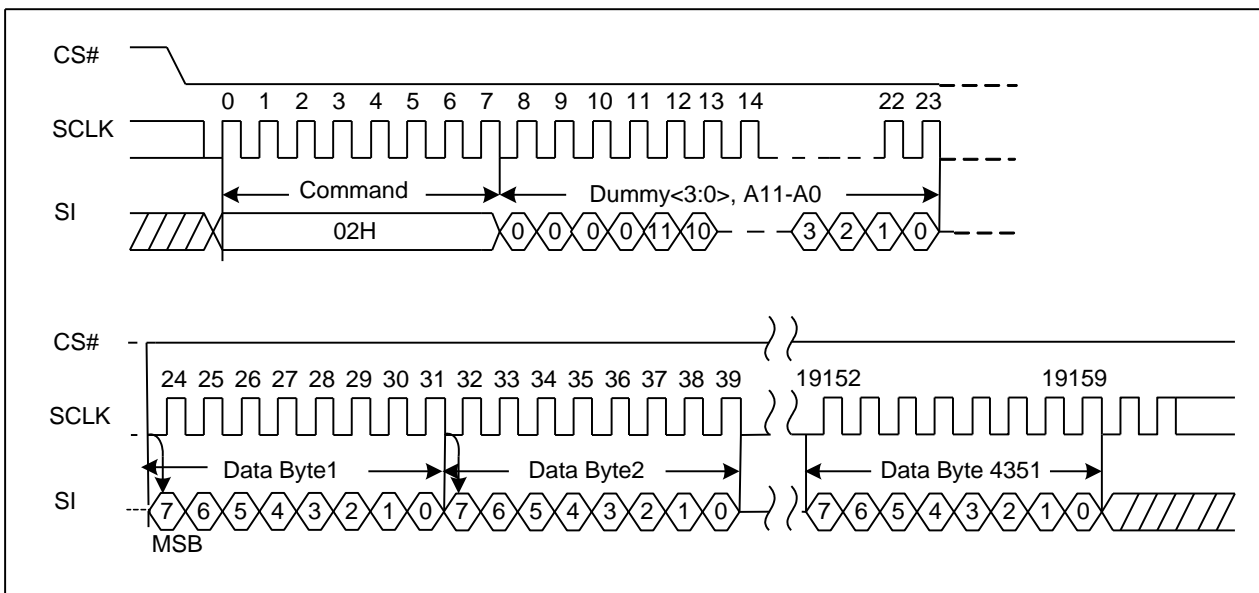

### 10.3 Program Load x4 (PL x4) (32H)

The Program Load x4 command (32H) is similar to the Program Load command (02H) but with the capability to input the data bytes by four pins: SIO0, SIO1, SIO2, and SIO3. The command sequence is shown below. The Quad Enable bit (QE) of feature (B0[0]) must be set to enable the program load x4 command.

Figure16. Program Load x4 Sequence Diagram

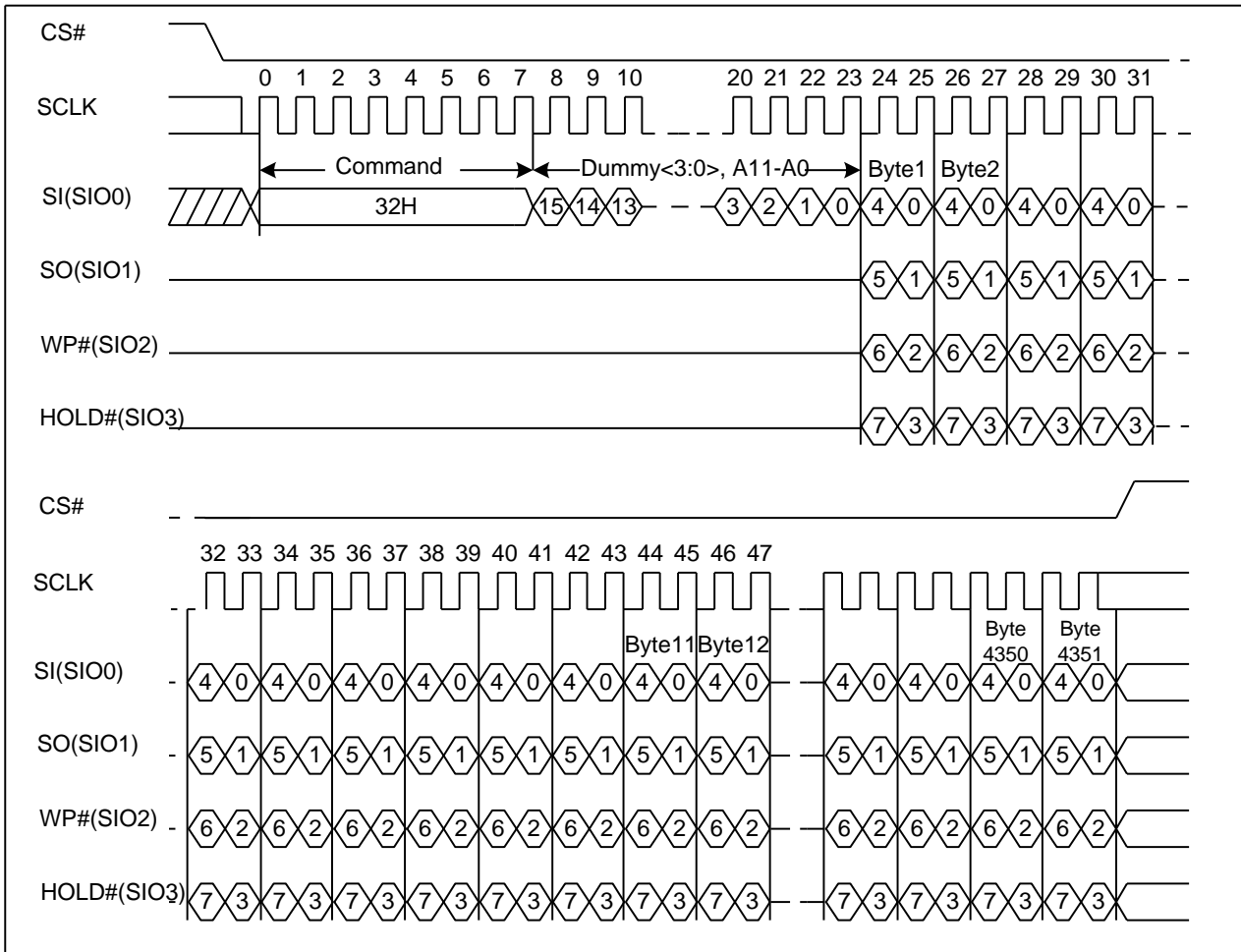

### 10.4 Program Execute (PE) (10H)

After the data is loaded, a PROGRAM EXECUTE (10H) command must be issued to initiate the transfer of data from the cache register to the main array. PROGRAM EXECUTE consists of an 8-bit Op code, followed by a 24-bit address. After the page/block address is registered, the memory device starts the transfer from the cache register to the main array, and is busy for tPROG time. This operation is shown in Figure18. During this busy time, the status register can be polled to monitor the status of the operation (refer to Status Register). When the operation completes successfully, the next series of data can be loaded with the PROGRAM LOAD command.

Figure17. Program Execute Sequence Diagram

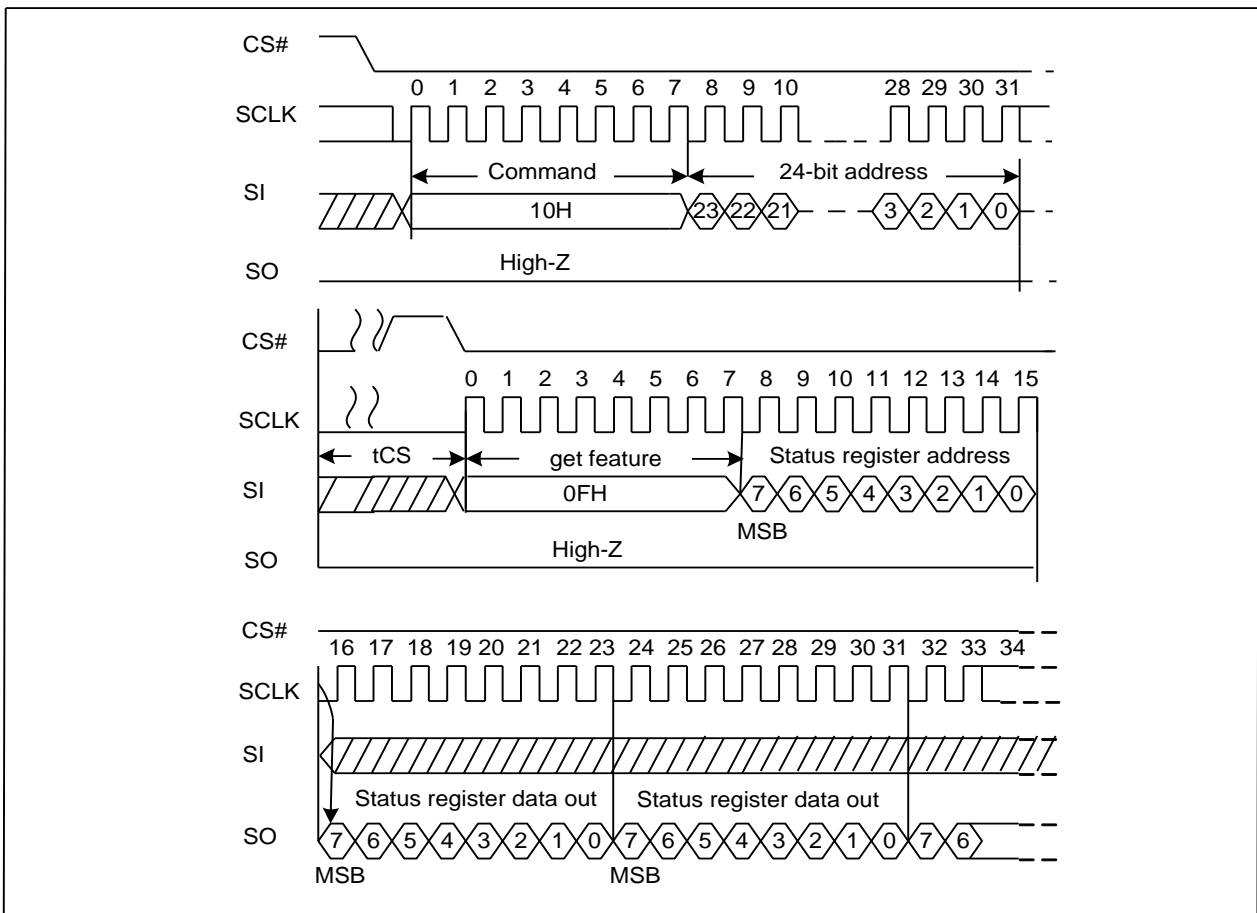



## 10.5 Internal Data Move

The INTERNAL DATA MOVE command sequence programs or replaces data in a page with existing data. The INTERNAL DATA MOVE command sequence is as follows:

- 13H (PAGE READ to cache)
- Optional 84H/C4H/34H(PROGRAM LOAD RANDOM DATA)
- 06H (WRITE ENABLE)
- 10H (PROGRAM EXECUTE)
- 0FH (GET FEATURE command to read the status)

Prior to performing an internal data move operation, the target page content must be read out into the cache register by issuing a PAGE READ (13H) command. The PROGRAM LOAD RANDOM DATA (84H/C4H/72H) command can be issued, if user wants to update bytes of data in the page. New data is loaded in the 12-bit column address. If the random data is not sequential, another PROGRAM LOAD RANDOM DATA (84H/C4H/72H) command must be issued with the new column address. After the data is loaded, the WRITE ENABLE command must be issued, and then a PROGRAM EXECUTE (10H) command can be issued to start the programming operation.

## 10.6 Program Load Random Data (84H)

This command consists of an 8-bit Op code, followed by 4 dummy bits, and a 12-bit column address. New data is loaded in the column address provided with the 12 bits. If the random data is not sequential, then another PROGRAM LOAD RANDOM DATA (84H) command must be issued with a new column address, see figure 20 for details. This command is only available during internal data move sequence.

Figure18. Program Load Random Data Sequence Diagram

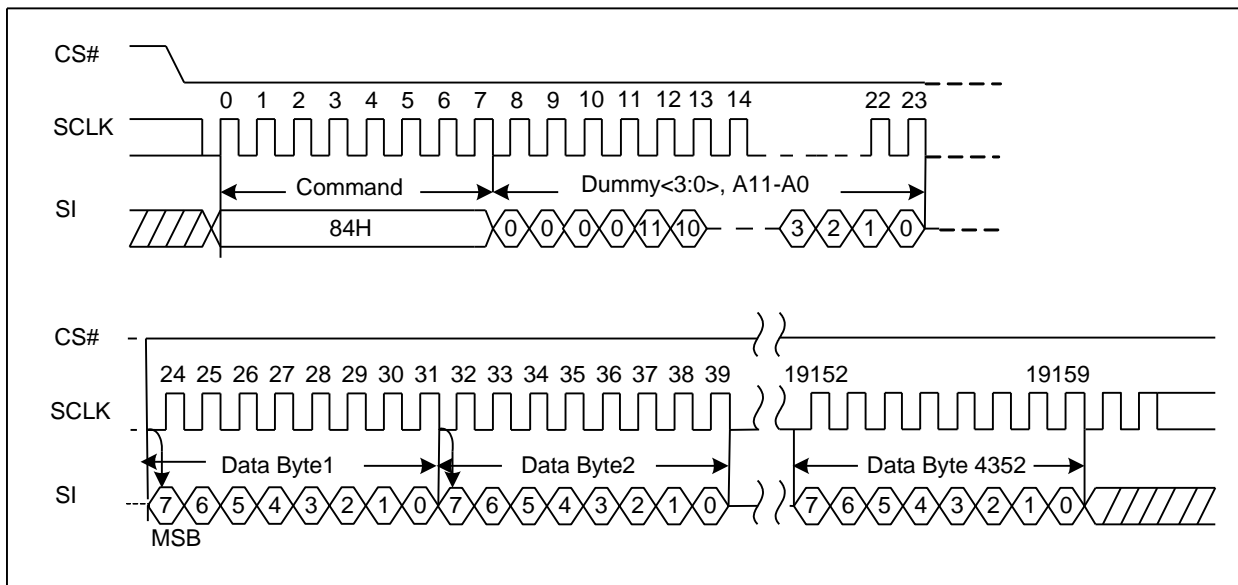

### 10.7 Program Load Random Data x4 (C4H/34H)

The Program Load Random Data x4 command (C4H/34H) is similar to the Program Load Random Data command (84H) but with the capability to input the data bytes by four pins: SIO0, SIO1, SIO2, and SIO3. The command sequence is shown below. The Quad Enable bit (QE) of feature (B0[0]) must be set to enable for the program load random data x4 command. See figure 21 for details. Those two commands are only available during internal data move sequence.

Figure19. Program Load Random Data x4 Sequence Diagram

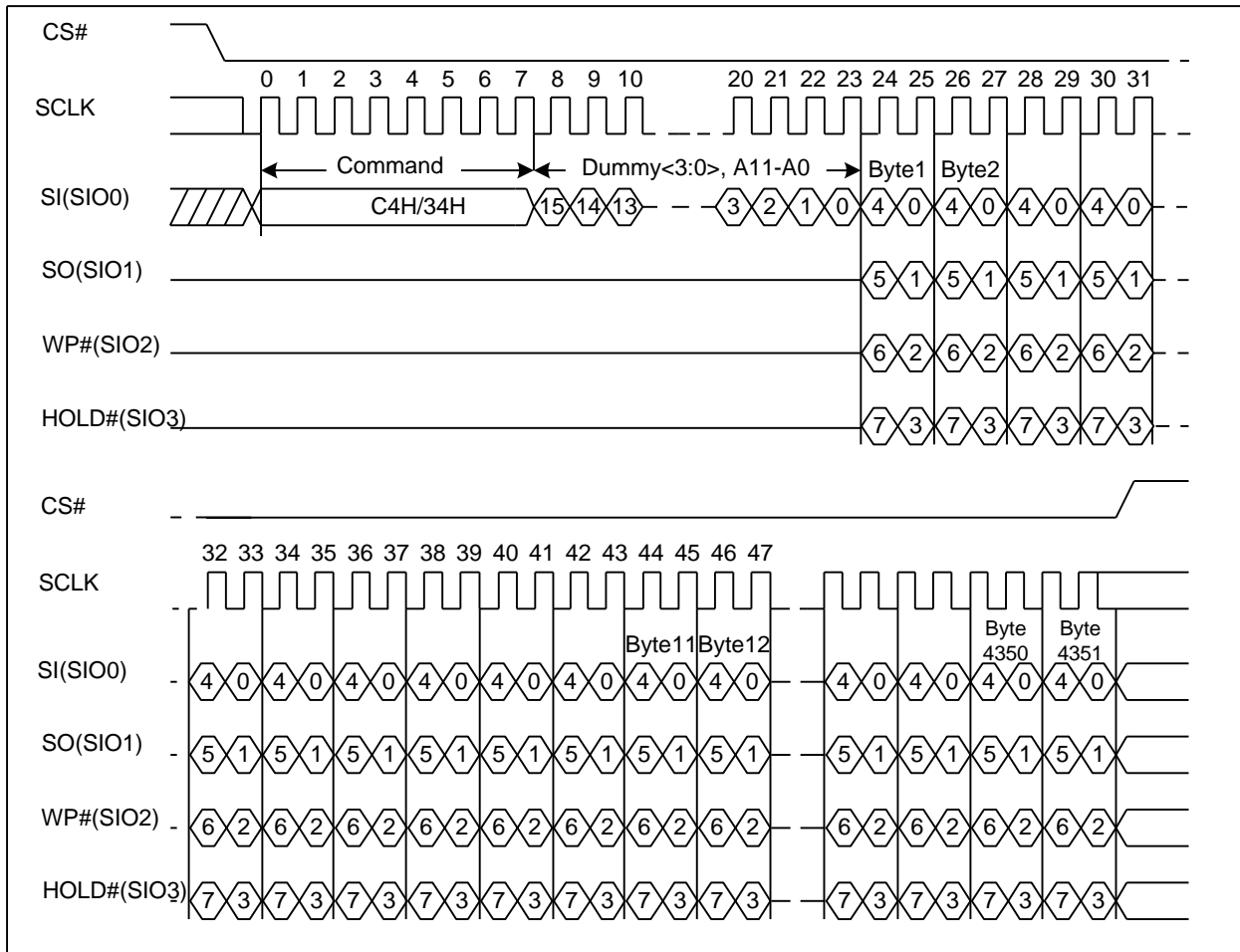

### 10.8 Program Load Random Data Quad IO (72H)

The Program Load Random Data Quad IO command (72H) is similar to the Program Load Random Data x4 command (C4H) but with the capability to input the 4 dummy bits, and a 12-bit column address by four pins: SIO0, SIO1, SIO2, and SIO3. The command sequence is shown below. The Quad Enable bit (QE) of feature (B0[0]) must be set to enable for the program load random data x4 command. See figure 22 for details. This command is only available during internal data move sequence.

Figure20. Program Load Random Data Quad IO Sequence Diagram

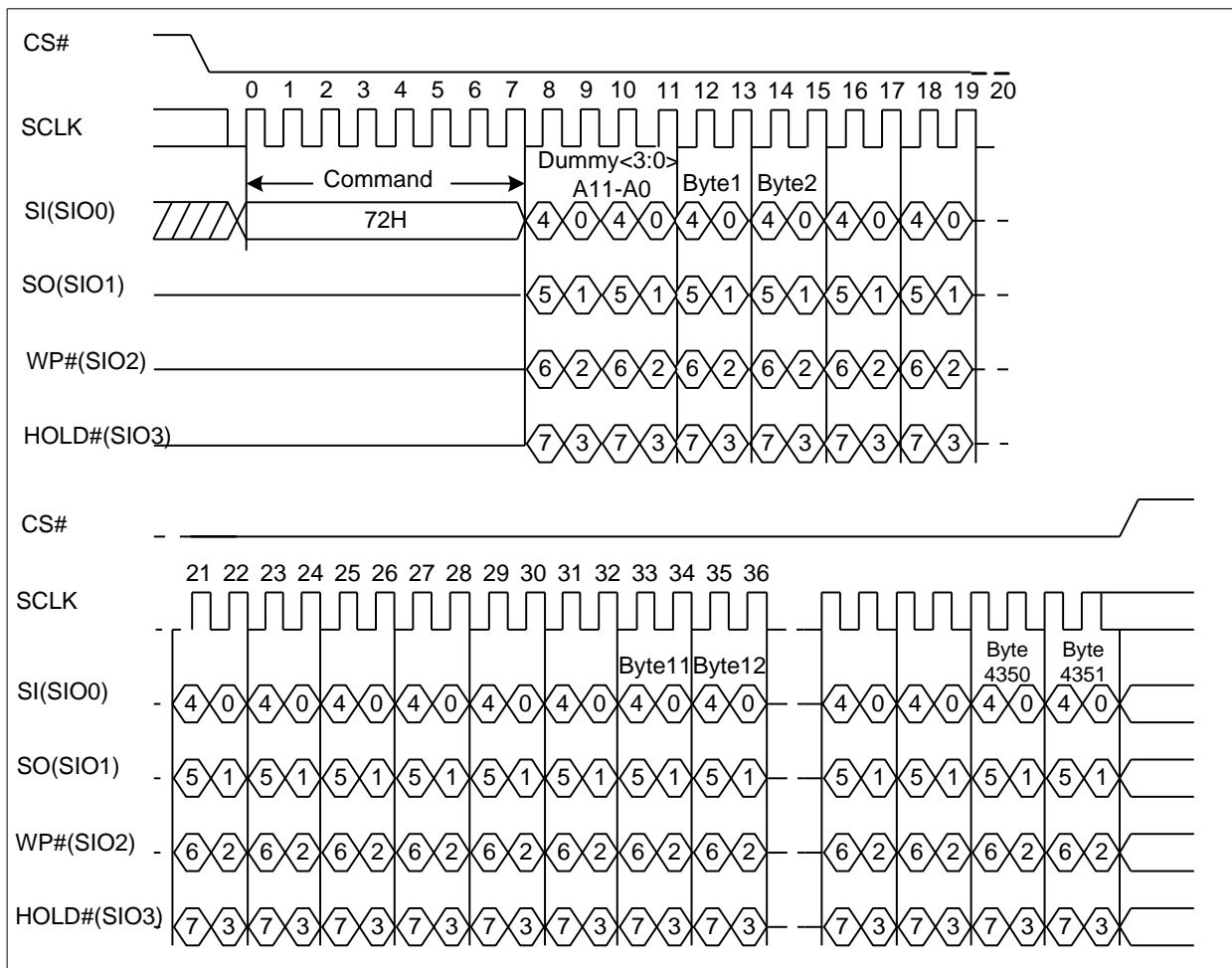

## 11 ERASE OPERATIONS

### 11.1 Block Erase (D8H)

Figure21. Block Erase Sequence Diagram

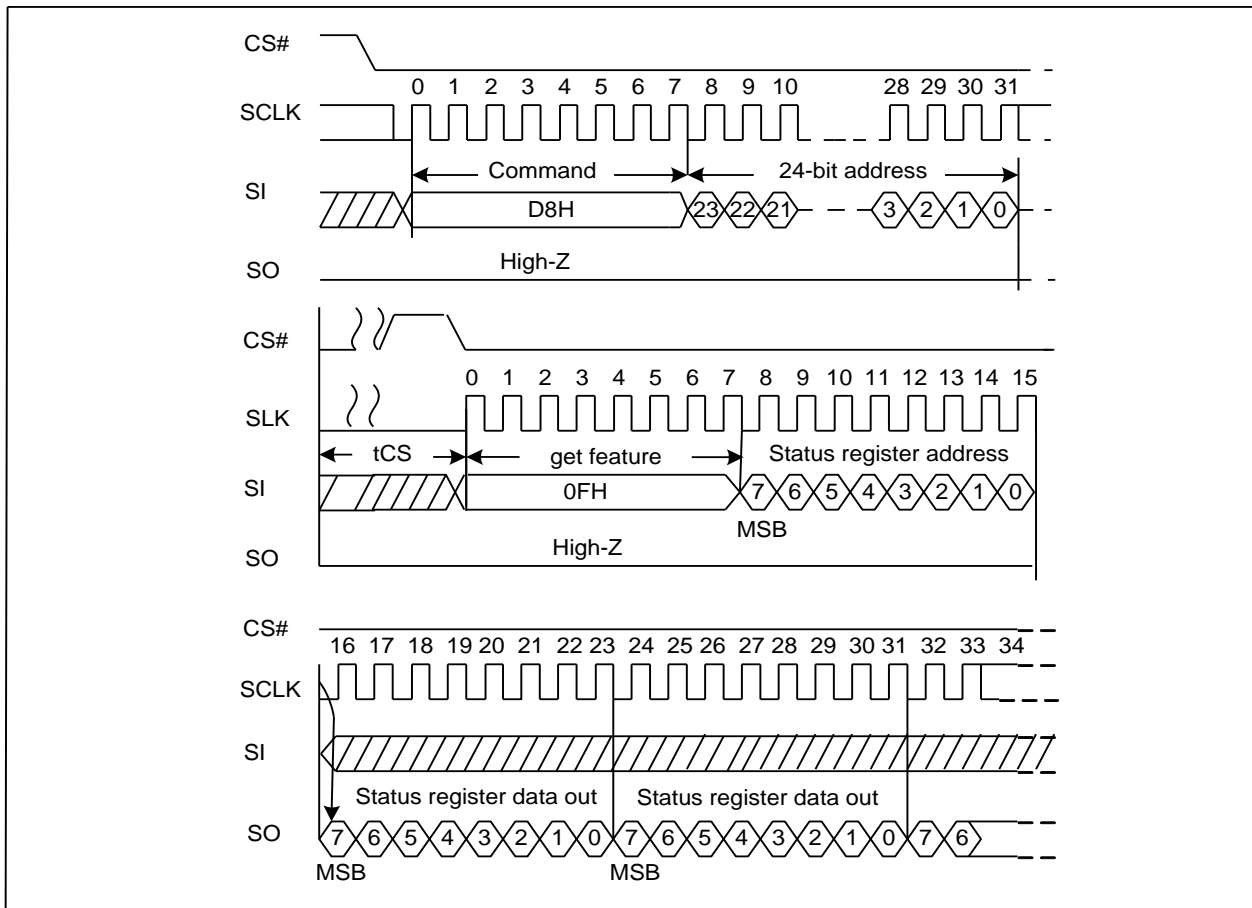

The BLOCK ERASE (D8H) command is used to erase at the block level. The blocks are organized as 64 pages per block, 2176 bytes per page (2048 + 128 bytes). Each block is 136 Kbytes. The BLOCK ERASE command (D8H) operates on one block at a time. The command sequence for the BLOCK ERASE operation is as follows:

- 06H (WRITE ENBALE command)
- D8H (BLOCK ERASE command)
- 0FH (GET FEATURES command to read the status register)

Prior to performing the BLOCK ERASE operation, a WRITE ENABLE (06H) command must be issued. As with any command that changes the memory contents, the WRITE ENABLE command must be executed in order to set the WEL bit. If the WRITE ENABLE command is not issued, then the rest of the erase sequence is ignored. A WRITE ENABLE command must be followed by a BLOCK ERASE (D8H) command. This command requires a 24-bit address. After the row address is registered, the control logic automatically controls timing and erase-verify operations. The device is busy for  $t_{ERS}$  time during the BLOCK ERASE operation. The GET FEATURES (0FH) command can be used to monitor the status of the operation.

When a block erase operation is in progress, user can issue normal read from cache commands (03H/0BH/3BH/6BH/BBH/EBH) to read the data in the cache.

## 12 RESET OPERATIONS

### 12.1 Reset (FFH)

Figure22. Reset Sequence Diagram

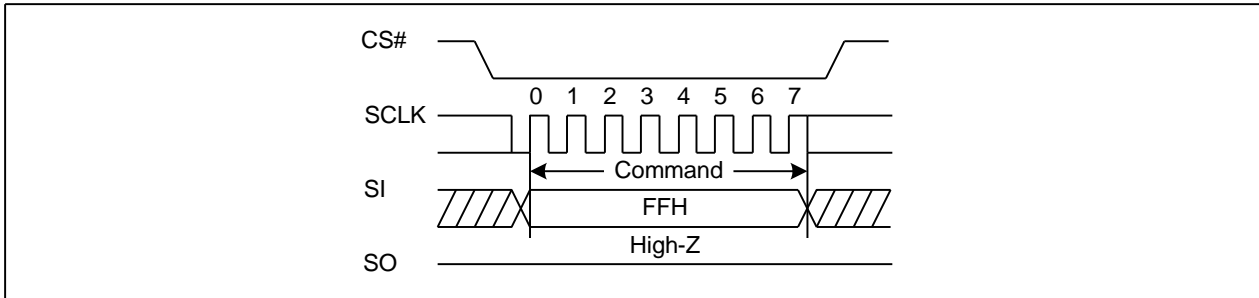

The RESET (FFH) command stops all operations. For example, in case of a program or erase or read operation, the reset command can make the device enter the wait state.

During a cache program or cache read, a reset can also stop the previous operation and the pending operation. The OIP status can be read from 300ns after the reset command is sent.

## 13 ADVANCED FEATURES

### 13.1 OTP Region

The serial device offers a protected, One-Time Programmable NAND Flash memory area. 4 full pages (2176 bytes per page) are available on the device. Customers can use the OTP area any way they want, like programming serial numbers, or other data, for permanent storage. When delivered from factory, feature bit OTP\_PRT is 0.

To access the OTP feature, the user must set feature bits OTP\_EN/OTP\_PRT by SET FEATURES command. When the OTP is ready for access, pages 00h–03H can be programmed in sequential order by PROGRAM LOAD (02H) and PROGRAM EXECUTE (10H) commands (when not yet protected), and read out by PAGE READ (13H) command and output data by READ from CACHE(03H/0BH/3BH/6BH/BBH/EBH).

**Table5. OTP States**

OTP_PRT	OTP_EN	State
x	0	Normal operation
0	1	Access OTP region, read and program data.
1	1	1. When the device power on state OTP_PRT is 0, user can set feature bit OTP_PRT and OTP_EN to 1, then issue PROGRAM EXECUTE (10H) to lock OTP, and after that OTP_PRT will permanently remain 1. 2. When the device power on state OTP_PRT is 1, user can only read the OTP region data.

Note: The OTP space cannot be erased and after it has been protected, it cannot be programmed again, please use this function carefully.

#### Access to OTP data

- Issue the SET FEATURES command (1FH)
- Set feature bit OTP\_EN
- Issue the PAGE PROGRAM (only when OTP\_PRT is 0) or PAGE READ command

#### Protect OTP region

Only when the following steps are completed, the OTP\_PRT will be set and users can get this feature out with 0FH command.

- Issue the SET FEATURES command (1FH)
- Set feature bit OTP\_EN and OTP\_PRT
- 06H (WRITE ENABLE)
- Issue the PROGRAM EXECUTE (10H) command.

## 13.2 Block Protection

The block lock feature provides the ability to protect the entire device, or ranges of blocks, from the PROGRAM and ERASE operations. After power-up, the device is in the “locked” state, i.e., feature bits BP0, BP1 and BP2 are set to 1, INV, CMP and BRWD are set to 0. To unlock all the blocks, or a range of blocks, the SET FEATURES command must be issued to alter the state of protection feature bits. When BRWD is set and WP# is LOW, none of the writable protection feature bits can be set. Also, when a PROGRAM/ERASE command is issued to a locked block, status bit OIP remains 0. When an ERASE command is issued to a locked block, the erase failure, 04H, is returned. When a PROGRAM command is issued to a locked block, program failure, 08h, is returned.

**Table6. Block Lock Register Block Protect Bits**

CMP	INV	BP2	BP1	BP0	Protect Row Address		Protect Rows
					1G	2G	
x	x	0	0	0	NONE	NONE	None—all unlocked
0	0	0	0	1	FC00h ~ FFFFh	1F800h ~ 1FFFFh	Upper 1/64 locked
0	0	0	1	0	F800h ~ FFFFh	1F000h ~ 1FFFFh	Upper 1/32 locked
0	0	0	1	1	F000h ~ FFFFh	1E000h ~ 1FFFFh	Upper 1/16 locked
0	0	1	0	0	E000h ~ FFFFh	1C000h ~ 1FFFFh	Upper 1/8 locked
0	0	1	0	1	C000h ~ FFFFh	18000h ~ 1FFFFh	Upper 1/4 locked
0	0	1	1	0	8000h ~ FFFFh	10000h ~ 1FFFFh	Upper 1/2 locked
x	x	1	1	1	0000h ~ FFFFh	0000h ~ 1FFFFh	All locked (default)
0	1	0	0	1	0000h ~ 03FFh	0000h ~ 7FFh	Lower 1/64 locked
0	1	0	1	0	0000h ~ 03FFh	0000h ~ FFFh	Lower 1/32 locked
0	1	0	1	1	0000h ~ 0FFFh	0000h ~ 1FFFh	Lower 1/16 locked
0	1	1	0	0	0000h ~ 1FFFh	0000h ~ 3FFFh	Lower 1/8 locked
0	1	1	0	1	0000h ~ 3FFFh	0000h ~ 7FFFh	Lower 1/4 locked
0	1	1	1	0	0000h ~ 7FFFh	0000h ~ FFFFh	Lower 1/2 locked
1	0	0	0	1	0000h ~ FBFFh	0000h ~ 1F7FFh	Lower 63/64 locked
1	0	0	1	0	0000h ~ F7FFh	0000h ~ 1EFFFh	Lower 31/32 locked
1	0	0	1	1	0000h ~ EFFFh	0000h ~ 1DFFFh	Lower 15/16 locked
1	0	1	0	0	0000h ~ DFFFh	0000h ~ 1BFFFh	Lower 7/8 locked
1	0	1	0	1	0000h ~ BFFFh	0000h ~ 17FFFh	Lower 3/4 locked
1	0	1	1	0	0000h ~ 003Fh	0000h ~ 003Fh	Block0
1	1	0	0	1	0400h ~ FFFFh	0800h ~ 1FFFFh	Upper 63/64 locked
1	1	0	1	0	0800h ~ FFFFh	1000h ~ 1FFFFh	Upper 31/32 locked
1	1	0	1	1	1000h ~ FFFFh	2000h ~ 1FFFFh	Upper 15/16 locked
1	1	1	0	0	2000h ~ FFFFh	4000h ~ 1FFFFh	Upper 7/8 locked
1	1	1	0	1	4000h ~ FFFFh	8000h ~ 1FFFFh	Upper 3/4 locked
1	1	1	1	0	0000h ~ 003Fh	0000h ~ 003Fh	Block0

When WP# is not LOW, user can issue bellows commands to alter the protection states as want.

- Issue SET FEATURES register write (1FH)
- Issue the feature bit address (A0h) and the feature bits combination as the table

### 13.3 Status Register and Driver Register

The NAND Flash device has an 8-bit status register that software can read during the device operation for operation state query. The status register can be read by issuing the GET FEATURES (0FH) command, followed by the feature address C0h or F0h (see FEATURE OPERATION). The Output Driver Register can be set and read by issuing the SET FEATURE (0FH) and GET FEATURE command followed by the feature address D0h (see FEATURE OPERATION).

**Table7. Status Register Bit Descriptions**

Bit	Bit Name	Description
P_FAIL	Program Fail	This bit indicates that a program failure has occurred (P_FAIL set to 1). It will also be set if the user attempts to program an invalid address or a protected region, including the OTP area. This bit is cleared during the PROGRAM EXECUTE command sequence or a RESET command (P_FAIL = 0).
E_FAIL	Erase Fail	This bit indicates that an erase failure has occurred (E_FAIL set to 1). It will also be set if the user attempts to erase a locked region. This bit is cleared (E_FAIL = 0) at the start of the BLOCK ERASE command sequence or the RESET command.
WEL	Write Enable Latch	This bit indicates the current status of the write enable latch (WEL) and must be set (WEL = 1), prior to issuing a PROGRAM EXECUTE or BLOCK ERASE command. It is set by issuing the WRITE ENABLE command. WEL can also be disabled (WEL = 0), by issuing the WRITE DISABLE command.
OIP	Operation In Progress	This bit is set (OIP = 1 ) when a PROGRAM EXECUTE, PAGE READ, BLOCK ERASE, or RESET command is executing, indicating the device is busy. When the bit is 0, the interface is in the ready state.
ECCS1, ECCS0 ECCSE1 ECCSE0	ECC Status	ECCS provides ECC status as the following table. ECCS and ECCSE are set to 00b either following a RESET, or at the beginning of the READ. They are then updated after the device completes a valid READ operation. ECCS and ECCSE are invalid if internal ECC is disabled (via a SET FEATURES command to reset ECC_EN to 0). After power-on RESET, ECC status is set to reflect the contents of block 0, page 0.

**Table8. Driver Register Bits Descriptions**

ECCS1	ECCS0	ECCSE1	ECCSE0	Description
0	0	x	x	No bit errors were detected during the previous read algorithm.
0	1	0	0	Bit errors( $\leq 4$ ) were detected and corrected.
0	1	0	1	Bit errors(=5) were detected and corrected.
0	1	1	0	Bit errors(=6) were detected and corrected.
0	1	1	1	Bit errors(=7) were detected and corrected.
1	0	x	x	Bit errors greater than ECC capability(8 bits) and not corrected
1	1	x	x	Bit errors reach ECC capability( 8 bits) and corrected



Table9. Driver Register Bits Descriptions

DS_S1	DS_S0	Driver Strength
0	0	50%
0	1	25%
1	0	75%
1	1	100%

### 13.4 Assistant Bad Block Management

As a NAND Flash, the device may have blocks that are invalid when shipped from the factory, and a minimum number of valid blocks ( $N_{VB}$ ) of the total available blocks are specified. An invalid block is one that contains at least one page that has more bad bits than can be corrected by the minimum required ECC. Additional bad blocks may develop with use. However, the total number of available blocks will not fall below  $N_{VB}$  during the endurance life of the product.

Although NAND Flash memory devices may contain bad blocks, they can be used reliably in systems that provide bad-block management and error-correction algorithms, which ensure data integrity. Internal circuitry isolates each block from other blocks, so the presence of a bad block does not affect the operation of the rest of the NAND Flash array.

NAND Flash devices are shipped from the factory erased. The factory identifies invalid blocks before shipping by programming the Bad Block Mark (00h) to the first spare area location in each bad block. This method is compliant with ONFI Factory Defect Mapping requirements. See the following table for the bad-block mark.

System software should initially check the first spare area location for non-FFH data on the first page of each block prior to performing any program or erase operations on the NAND Flash device. A bad-block table can then be created, enabling system software to map around these areas. Factory testing is performed under worst-case conditions. Because invalid blocks may be marginal, it may not be possible to recover the bad-block marking if the block is erased.

To simplify the system requirement and guard the data integration, GigaDevice SPI NAND provides assistant Management options as below.

Table10. Bad Block Mark information

Description	Density	Requirement
Minimum number of valid blocks ( $N_{VB}$ )	1G	1004
	2G	2008
Total available blocks per die	1G	1024
	2G	2048
First spare area location		Byte 2048
Bad-block mark		00h(use non FFH to check)

## 13.5 Internal ECC

The serial device offers data corruption protection by offering optional internal ECC. READs and PROGRAMs with internal ECC can be enabled or disabled by setting feature bit ECC\_EN. ECC is enabled after device power up, so the default READ and PROGRAM commands operate with internal ECC in the “active” state. To enable/disable ECC, perform the following command sequence:

- Issue the SET FEATURES command (1FH).
- Set the feature bit ECC\_EN as you want:
  1. To enable ECC, Set ECC\_EN to 1.
  2. To disable ECC, Clear ECC\_EN to 0.

During a PROGRAM operation, the device calculates an ECC code on the 2k page in the cache register, before the page is written to the NAND Flash array.

During a READ operation, the page data is read from the array to the cache register, where the ECC code is calculated and compared with the ECC code value read from the array. If error bits are detected, the error is corrected in the cache register. Only corrected data is output on the I/O bus. The ECC status bit indicates whether or not the error correction was successful. The ECC Protection table below shows the ECC protection scheme used throughout a page.

With internal ECC, the user must accommodate the following:

- Spare area definitions provided in the ECC Protection table below. User meta data I is not protected by internal ECC and User meta data II is protected by internal ECC.
- ECC can protect main data and spare areas data. Any data wrote to the ECC area are ignored.

**Table11. ECC Protection and Spare Area**

Max Byte Address	Min Byte Address	ECC Protected	Area	Description
1FFH	000H	Yes	Main 0	User data 0
3FFH	200H	Yes	Main 1	User data 1
5FFH	400H	Yes	Main 2	User data 2
7FFH	600H	Yes	Main 3	User data 3
803H	800H	No	Spare 0	User meta 0 data I <sup>(1)</sup>
80FH	804H	Yes	Spare 0	User meta 0 data II
813H	810H	No	Spare 1	User meta 1 data I
81FH	814H	Yes	Spare 1	User meta 1 data II
823H	820H	No	Spare 2	User meta 2 data I
82FH	824H	Yes	Spare 2	User meta 2 data II
833H	830H	No	Spare 3	User meta 3 data I
83FH	834H	Yes	Spare 3	User meta 3 data II
87FH	840H	Yes	Spare area	Internal ECC parity data

Note1: 800H is reserved for initial bad block mark

## 14 POWER ON TIMING

Figure23. Power on Timing Sequence

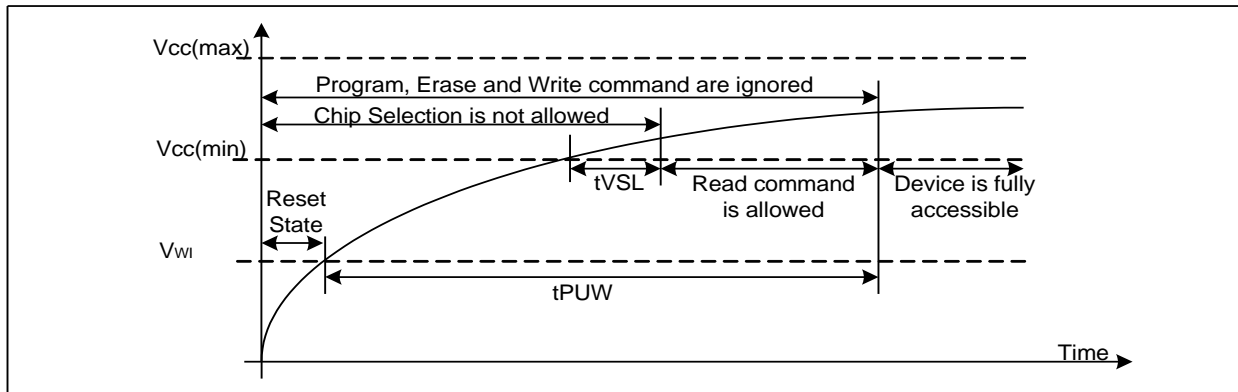

Table12. Power-On Timing and Write Inhibit Threshold for 1.8V/3.3V

Symbol	Parameter	Min	Max	Unit
tVSL	VCC(min) To CS# Low	1		ms
tPUW	Time Delay From VCC(Vwi) To Write Instruction	5		ms
VWI	Write Inhibit Voltage	1.8V	1.7	V
		3.3V	2.5	

**15 ABSOLUTE MAXIMUM RATINGS**

Parameter	Value	Unit
Ambient Operating Temperature	-40 to 85	°C
Storage Temperature	-55 to 125	°C
Applied Input/Output Voltage	-0.6 to V <sub>cc</sub> +0.4	V
VCC	-0.6 to V <sub>cc</sub> +0.4	V

## 16 CAPACITANCE MEASUREMENT CONDITIONS

Symbol	Parameter	Min	Typ	Max	Unit	Conditions
CIN	Input Capacitance			6	pF	VIN=0V
COUT	Output Capacitance			8	pF	VOUT=0V
CL	Load Capacitance	30			pF	
	Input Rise And Fall time			5	ns	
	Input Pulse Voltage	0.1VCC to 0.8VCC			V	
	Input Timing Reference Voltage	0.2VCC to 0.7VCC			V	
	Output Timing Reference Voltage	0.5VCC			V	

Figure24. Input Test Waveform and Measurement Level

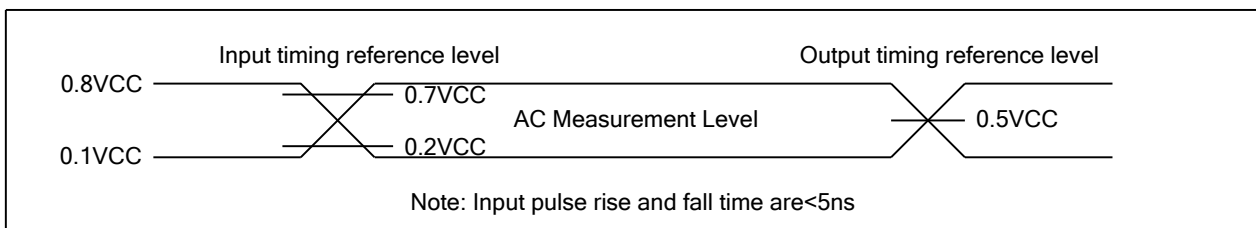

**17 DC CHARACTERISTIC**

(T= -40°C~85°C, VCC=1.7~2.0V/2.7~3.6V)

Symbol	Parameter	Test Condition	Min.	Typ	Max.	Unit.
I <sub>LI</sub>	Input Leakage Current				±2	μA
I <sub>LO</sub>	Output Leakage Current				±2	μA
I <sub>CC1</sub>	Standby Current	CS#=VCC, V <sub>IN</sub> =VCC or VSS			70	μA
I <sub>CC2</sub>	Operating Current (Read)	CLK=0.1VCC / 0.9VCC at 108MHz, Q=Open(*1,*2,*4 I/O)			40	mA
		CLK=0.1VCC / 0.9VCC at 80MHz, Q=Open(*1,*2,*4 I/O)			30	mA
I <sub>CC3</sub>	Operation Current (PP)	CS#=VCC			40	mA
I <sub>CC4</sub>	Operation Current (BE)	CS#=VCC			40	mA
V <sub>IL</sub>	Input Low Voltage				0.2VCC	V
V <sub>IH</sub>	Input High Voltage		0.7VCC			V
V <sub>OL</sub>	Output Low Voltage	I <sub>OL</sub> =1.6mA			0.4	V
V <sub>OH</sub>	Output High Voltage	I <sub>OH</sub> =-100μA	VCC-0.2			V

## 18 AC CHARACTERISTICS

(T= -40°C~85°C, VCC=1.7~2.0V/2.7~3.6V, CL=30pf)

Symbol	Parameter	Min.	Typ.	Max.	Unit.
F <sub>C</sub>	Serial Clock Frequency For: all command	DC.		120	MHz
t <sub>CH</sub>	Serial Clock High Time	4			ns
t <sub>CL</sub>	Serial Clock Low Time	4			ns
t <sub>CLCH</sub>	Serial Clock Rise Time (Slew Rate)	0.2			V/ns
t <sub>CHCL</sub>	Serial Clock Fall Time (Slew Rate)	0.2			V/ns
t <sub>SLCH</sub>	CS# Active Setup Time	5			ns
t <sub>CHSH</sub>	CS# Active Hold Time	5			ns
t <sub>SHCH</sub>	CS# Not Active Setup Time	5			ns
t <sub>CHSL</sub>	CS# Not Active Hold Time	5			ns
t <sub>SHSL</sub> /t <sub>CS</sub>	CS# High Time	20			ns
t <sub>SHQZ</sub>	Output Disable Time			20	ns
t <sub>CLQX</sub>	Output Hold Time	0			ns
t <sub>DVCH</sub>	Data In Setup Time	2			ns
t <sub>CHDX</sub>	Data In Hold Time	2			ns
t <sub>HLCH</sub>	Hold# Low Setup Time (relative to Clock)	5			ns
t <sub>HHCH</sub>	Hold# High Setup Time (relative to Clock)	5			ns
t <sub>CHHL</sub>	Hold# High Hold Time (relative to Clock)	5			ns
t <sub>CHHH</sub>	Hold# Low Hold Time (relative to Clock)	5			ns
t <sub>HLQZ</sub>	Hold# Low To High-Z Output			15	ns
t <sub>HHQX</sub>	Hold# High To Low-Z Output			15	ns
t <sub>CLQV</sub>	Clock Low To Output Valid			8	ns
t <sub>WHSL</sub>	WP# Setup Time Before CS# Low	20			ns
t <sub>SHWL</sub>	WP# Hold Time After CS# High	100			ns

## 19 PERFORMANCE TIMING

Symbol	Parameter	Min.	Typ.	Max.	Unit.
t <sub>RST</sub>	CS# High To Next Command After Reset(FFh)			500	us
t <sub>RD</sub>	Read From Array			80	us
t <sub>PROG</sub>	Page Programming Time		0.4	0.7	ms
t <sub>BERS</sub>	Block Erase Time		3	5	ms

Figure25. Serial Input Timing

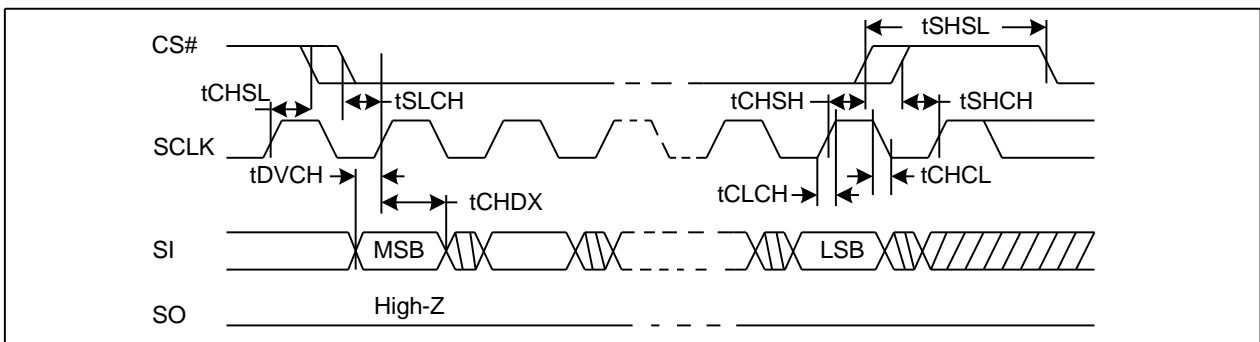

Figure26. Output Timing

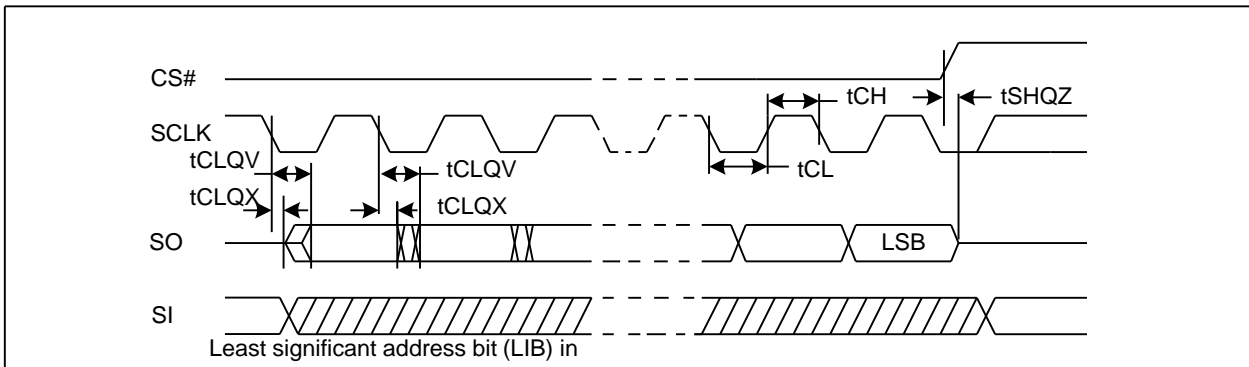

Figure27. Hold Timing

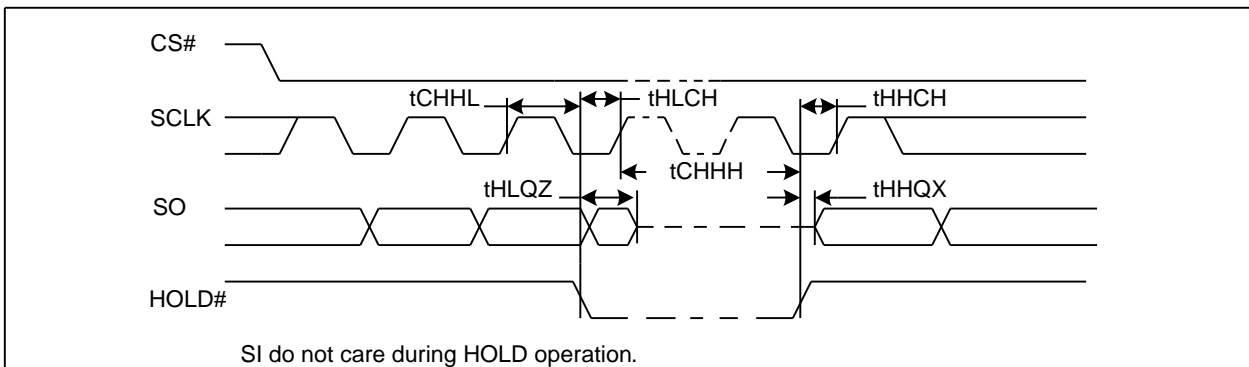
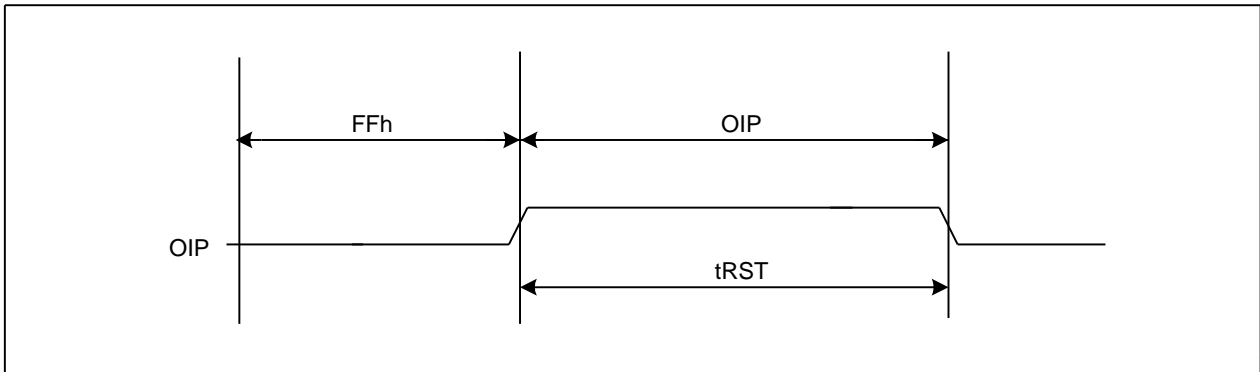



Figure28. Reset Timing



Note: The maximum tRST depends on different operations.

- Idle: maximum tRST = 5us;
- Read: maximum tRST = 5us;
- Program: maximum tRST = 10us;
- Erase: maximum tRST = 500us;

20 ORDERING INFORMATION

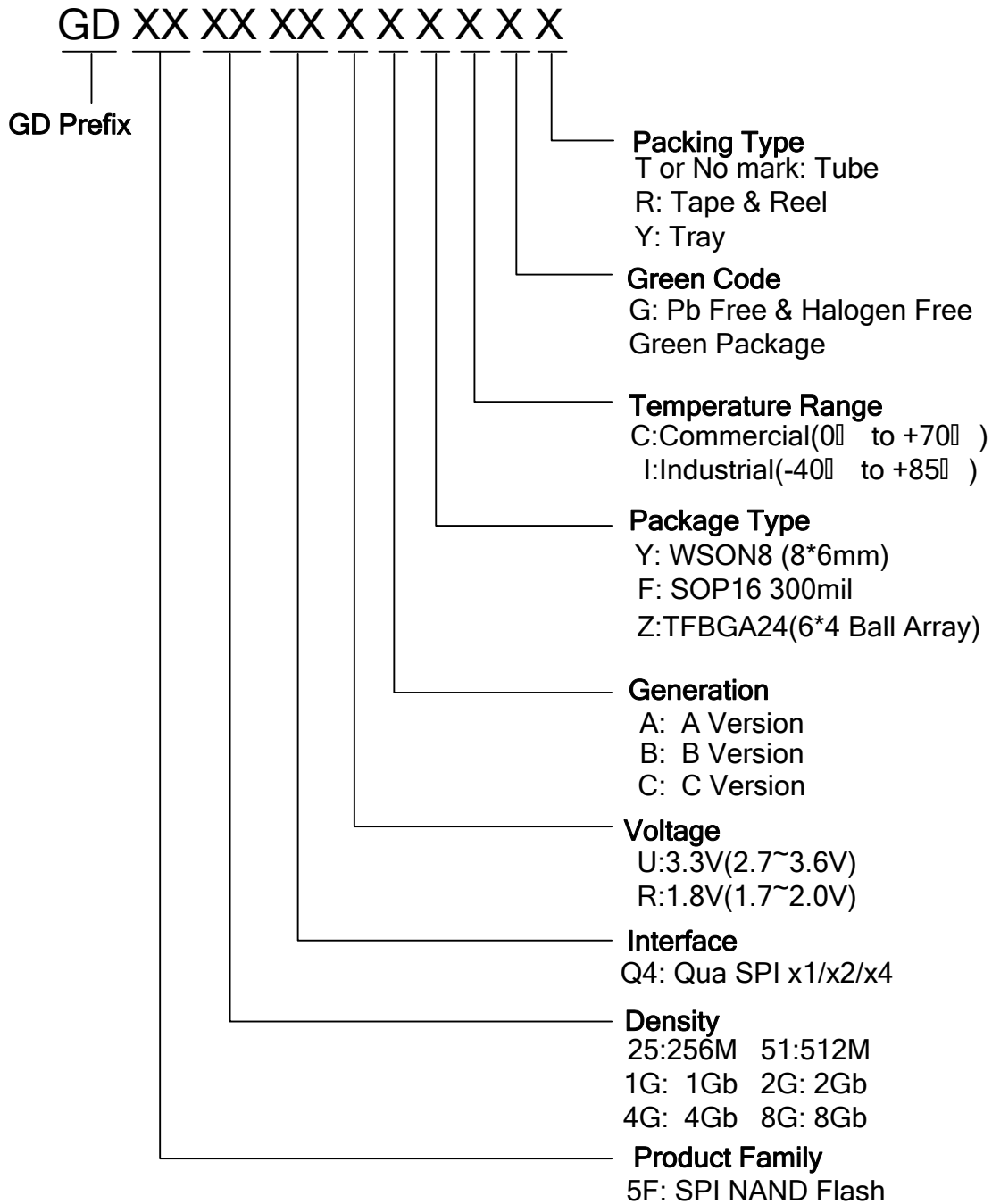

## 21 PACKAGE INFORMATION

Figure29. WSON8 (8\*6mm)

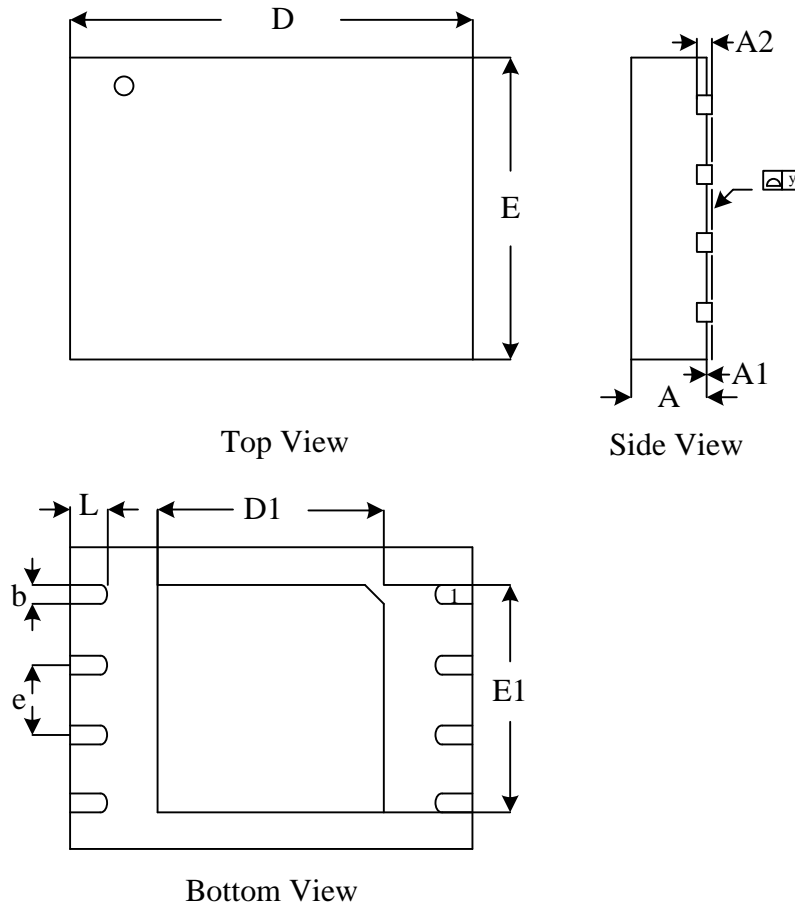

### Dimensions

Symbol		A	A1	A2	b	D	D1	E	E1	e	y	L
Unit												
mm	Min	0.70			0.35	7.95	3.25	5.95	4.15		0.00	0.40
	Nom	0.75		0.20	0.40	8.00	3.40	6.00	4.30	1.27		0.50
	Max	0.80	0.05		0.45	8.05	3.50	6.05	4.40		0.05	0.60
Inch	Min	0.028			0.014	0.313	0.128	0.234	0.163		0.00	0.016
	Nom	0.030		0.008	0.016	0.315	0.134	0.236	0.169	0.05		0.020
	Max	0.032	0.002		0.019	0.317	0.138	0.238	0.173		0.002	0.024

Figure30. SOP16 300MIL

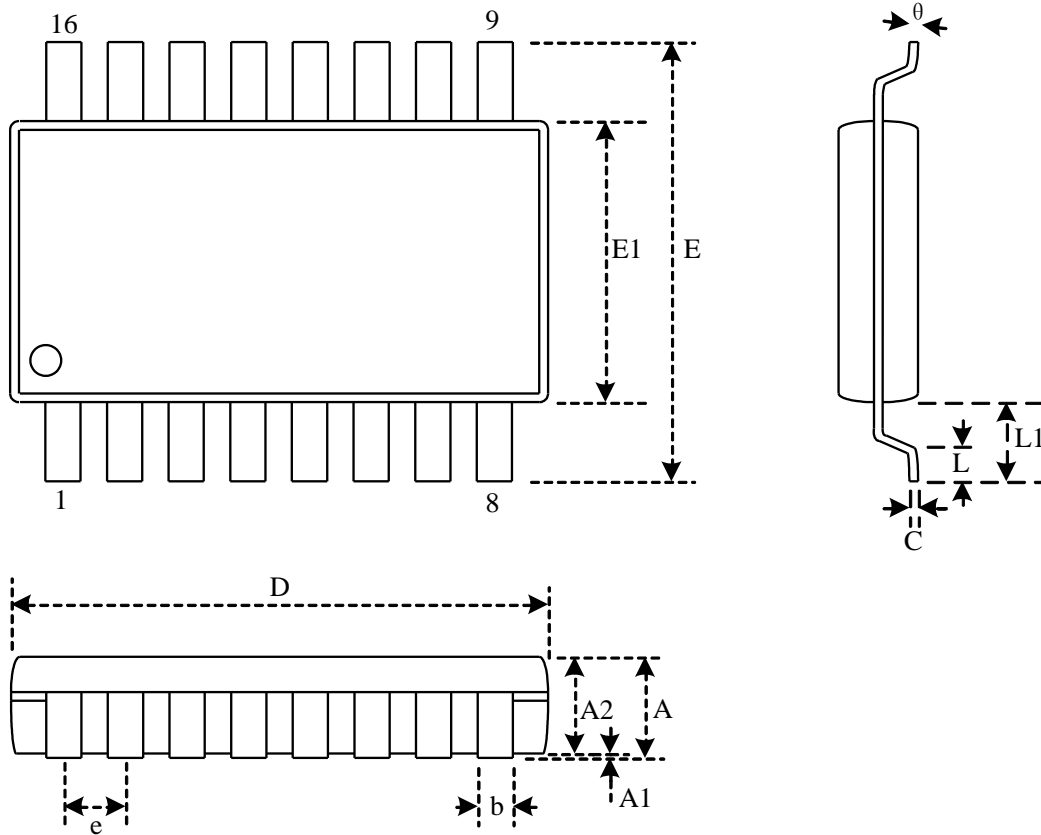

**Dimensions**

Symbol		A	A1	A2	b	C	D	E	E1	e	L	L1	S	$\theta$
Unit														
mm	Min	2.36	0.10	2.24	0.36	0.20	10.10	10.10	7.42		0.40	1.31	0.51	0
	Nom	2.55	0.20	2.34	0.41	0.25	10.30	10.35	7.52	1.27	0.84	1.44	0.64	5
	Max	2.75	0.30	2.44	0.51	0.30	10.50	10.60	7.60		1.27	1.57	0.77	8
Inch	Min	0.093	0.004	0.088	0.014	0.008	0.397	0.397	0.292		0.016	0.052	0.020	0
	Nom	0.100	0.008	0.092	0.016	0.010	0.405	0.407	0.296	0.050	0.033	0.057	0.025	5
	Max	0.108	0.012	0.096	0.020	0.012	0.413	0.417	0.299		0.050	0.062	0.030	8

Note: Both package length and width do not include mold flash.

Figure31. TFBGA-24BALL (6\*4 ball array)

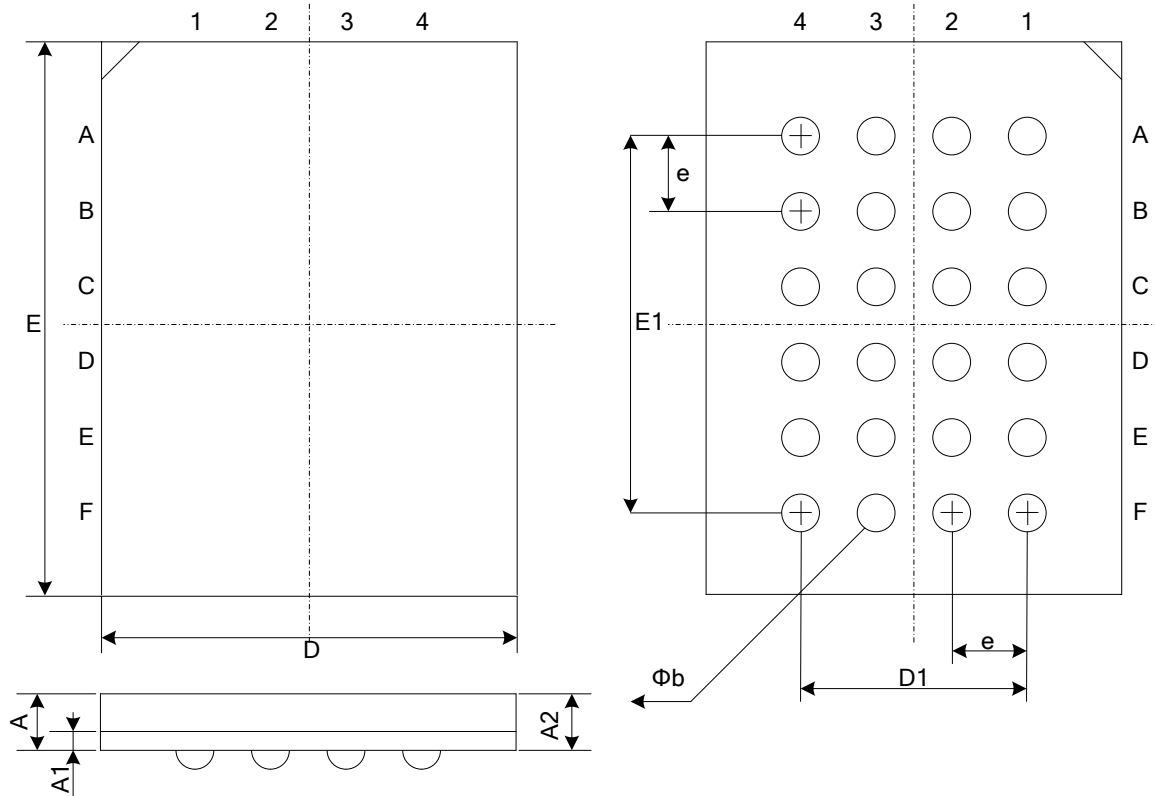

### Dimensions

Symbol		A	A1	A2	b	D	D1	E	E1	e
Unit										
mm	Min		0.25		0.35	5.90		7.90		
	Nom		0.30	0.85	0.40	6.00	3.00	8.00	5.00	1.00
	Max	1.20	0.35		0.45	6.10		8.10		
Inch	Min		0.010		0.014	0.232		0.311		
	Nom		0.012	0.033	0.016	0.236	0.120	0.315	0.200	0.039
	Max	0.047	0.014		0.018	0.240		0.319		

Note: Both package length and width do not include mold flash.

**22 REVISION HISTORY**

Version No	Description	Date
0.0	Initial Preliminary Release	Apr. 15, 2014
0.1	Serial Clock High Time change from 4.5ns to 4ns Serial Clock Low Time change from 4.5ns to 4ns	May 8, 2014
0.3	Change ECC protect table	Sep 9, 2014
0.4	Modify program time bug	Sep 24,2014
0.5	Delete SPI Modes note "do not toggle SCLK until CS# is driven LOW"	Feb 12,2015
1.0	Initial Release Modify DC CHARACTERISTIC, add I <sub>CC3</sub> and I <sub>CC4</sub>	Mar. 17,2015
1.1	Modify WSON8 (8*6mm)	Jun.23,2015
1.2	Add package TFBGA-24BALL (6*4 ball array)	Aug.12,2015